

Operating Manual

ZEEnit 650 P

Atomic Absorption Spectrometer



Manufacturer Analytik Jena GmbH
Konrad-Zuse-Str.1
07745 Jena · Germany
Phone + 49 3641 / 77 70
Fax + 49 3641 / 77 92 79
Email info@analytik-jena.com

Service Analytik Jena GmbH
Konrad-Zuse-Str. 1
07745 Jena · Germany
Phone + 49 3641 / 77-7407 (Hotline)
Email service@analytik-jena.com



For a proper and safe use of this product follow the instructions.
Keep the operating manual for future reference.

General information <http://www.analytik-jena.com>

Copyrights and
Trademarks Microsoft and Windows are registered trademarks of Microsoft Corp.
The identification with ® or TM is omitted in this manual.

Documentation number 150:702.23

Edition B (01/2021)

Implementation of the
Technical Documentation Analytik Jena GmbH

© Copyright 2021, Analytik Jena GmbH

Contents

1	Basic information	7
1.1	Intended use.....	7
1.2	Notes on the manual.....	7
2	Safety instructions	9
2.1	Proper use.....	9
2.2	Summary of safety instructions	9
2.3	Warning signs on the ZEEnit 650 P	14
3	Specifications	16
3.1	Technical data	16
3.1.1	Data for the ZEEnit 650 P	16
3.1.2	Minimum requirements of the ASpect LS software	21
3.1.3	Data for the graphite tube technique	21
3.1.4	Data on autosamplers for hydride and HydrEA techniques	22
3.2	Guidelines and standards	24
4	Installation conditions	25
4.1	Environmental conditions	25
4.2	Space requirement and weight.....	26
4.3	Energy supply.....	27
4.4	Gas supply / gases in the graphite tube technique	28
4.5	Exhaust unit.....	28
4.6	Water cooling	29
4.7	Device layout and space requirement	29
5	Function and setup of the ZEEnit 650 P	32
5.1	Function of the ZEEnit 650 P	32
5.1.1	AAS techniques with the ZEEnit 650 P.....	32
5.1.2	Optical principle	33
5.1.3	Measurement principle.....	34
5.2	Electrothermal atomizer with Zeeman magnet.....	37
5.2.1	The Zeeman graphite furnace	38
5.2.2	The Zeeman magnet	39
5.2.3	Gas flows	40
5.2.4	Graphite tube variations, furnace parts and inserts.....	41
5.2.5	Radiation sensor.....	42
5.2.6	Furnace camera	42
5.3	Accessories for the graphite tube technique	43
5.3.1	Autosampler AS-GF.....	43
5.3.2	Mobile cooling unit KM 5.....	44
5.3.3	Solid autosamplers SSA 600 and SSA6.....	44
5.4	Mercury/hydride systems	45
5.5	The autosamplers AS-F and AS-FD as an accessory for the hydride and HydrEA technique.....	45
5.6	Lamp turrets and lamps	47

6	Installation and start-up	48
6.1	Supply and control connections	48
6.2	Removing the transport lock	50
6.3	Installing the ZEEnit 650 P	51
6.4	Installing the mobile cooling unit KM 5	51
6.5	Installation and start of the ASpect LS program	52
6.6	Mounting the 8-lamp turret and lamp adjustment	52
6.6.1	Removing and installing the hollow cathode lamp	53
6.6.2	Removing and installing the deuterium hollow cathode lamp	54
6.6.3	Setting up the lamp turret in ASpect LS	55
6.6.4	Adjusting the lamps	57
6.7	Graphite tube technique	59
6.7.1	Connections in the sample chamber for the graphite tube technique	59
6.7.2	Software presettings for the graphite tube technique	59
6.7.3	Inserting the graphite tube into the graphite furnace	60
6.7.4	Formatting the graphite tube	62
6.7.5	Cleaning the graphite tube / (clean out)	62
6.8	Autosampler AS-GF	63
6.8.1	Completing and installing the autosampler	63
6.8.2	Adjusting the AS-GF	66
6.8.3	Populating the sample tray of the AS-GF	67
6.8.4	Uninstalling the autosampler AS-GF	68
6.9	Notes on installing the automatic solid autosampler SSA600	68
6.10	Installations for Hydride/HydrEA mode	68
6.10.1	Installing the cell unit for hydride systems	69
6.10.2	Installation for continuous hydride/HydrEA mode	69
6.11	Starting up the ZEEnit 650 P with accessories	72
6.11.1	Switching on sequence, daily work commencement	72
6.11.2	Switching off sequence	72
7	Care and maintenance	73
7.1	Maintenance overview	73
7.2	Base device	74
7.2.1	Changing the fuses	74
7.2.2	Cleaning of sample chambers	75
7.3	Graphite furnace	75
7.3.1	Maintaining the graphite furnace	75
7.3.2	Separation of the graphite furnace from the Zeeman magnet and reinsertion	77
7.3.3	Removing and cleaning the temperature sensor group	80
7.3.4	Replacing the upper electrode	81
7.3.5	Replacing the graphite tube shroud and the lower electrode	83
7.3.6	Cleaning and changing the graphite tube	85
7.4	Autosampler AS-GF	86
7.4.1	Washing the dosing tube	86
7.4.2	Servicing the dosing tube	87
7.4.3	Replacing the dosing device	89

7.4.4	Clean-up after cup overflow	90
7.5	Autosampler AS-F, AS-FD	90
7.5.1	Washing the mixing cup of the AS-FD.....	90
7.5.2	Replacing the canulas and guide on the autosampler arm of the AS-FD	91
7.5.3	Replacing the canula on the autosampler arm of the AS-F	91
7.5.4	Replacing the intake tube.....	92
7.5.5	Replacing the tube set at AS-FD.....	92
7.5.6	Clean-up after cup overflow	92
7.6	Mobile cooling unit KM 5.....	93
7.7	Supply connections.....	93
8	Transporting the ZEEnit 650 P	94
9	Waste disposal	95

Index of Figures

Fig. 1	Warning signs on the ZEEnit 650 P	15
Fig. 2	Dimensions of the ZEEnit 650 P - front view.....	30
Fig. 3	Dimensions of the ZEEnit 650 P - top view.....	30
Fig. 4	Installation layout of the ZEEnit 650 P	31
Fig. 5	ZEEnit 650 P	32
Fig. 6	Optical schematic of the ZEEnit 650P	33
Fig. 7	Basic principle of transversal inverse Zeeman atomic absorption spectroscopy	36
Fig. 8	Zeeman graphite furnace.....	38
Fig. 9	Graphite furnace, open	39
Fig. 10	Inner and outer gas flows in the graphite furnace	40
Fig. 11	Graphite tube variations.....	41
Fig. 12	Furnace shroud, adapters and inserts	41
Fig. 13	Autosampler AS-GF.....	43
Fig. 14	Solid autosamplers for ZEEnit.....	44
Fig. 15	Setup of the lamp turret	47
Fig. 16	Mains switch and bar for supply and control connections on the right side of the ZEEnit 650 P	49
Fig. 17	Bar for supply and control connections.....	49
Fig. 18	Rear view of the ZEEnit 650 P with connections for the supply of gas, electricity and water, as well as the fuse holders	50
Fig. 19	Setup of the lamp turret	53
Fig. 20	D2HCL holder installed in the lamp chamber.....	54
Fig. 21	D2HCL with the holder removed from the lamp chamber and positioned for lamp change	55
Fig. 22	Select lamp/element window.....	56
Fig. 23	Lamp turret window	57
Fig. 24	Spectrometer window - Energy	58
Fig. 25	Elements in the sample chamber for the graphite tube technique	59
Fig. 26	Start menu of ASpect LS with settings for the graphite tube	60
Fig. 27	Furnace - Control window	60
Fig. 28	Graphite furnace opened with inserted graphite tube.....	61
Fig. 29	Installing the AS-GF.....	64
Fig. 30	Aligning the AS-GF with the furnace using the set screw and adjusting screw.....	65
Fig. 31	AS-GF adjustment	66
Fig. 32	Position of eccentric roll on the SSA 600.....	68
Fig. 33	Support and cell unit for hydride system on the ZEEnit 650 P.....	69

Fig. 34	Hydride system HS 60 modular for hydride/HydrEA measurements..	69
Fig. 35	Rear of the autosampler AS-FD	70
Fig. 36	Dosing unit at the Fluidics module of the AS-FD.....	71
Fig. 37	Locking screws for the graphite furnace	77
Fig. 38	Driven-out furnace, right side	78
Fig. 39	Driven-out furnace	78
Fig. 40	Driven-out furnace, open, left side.....	79
Fig. 41	Driven-out furnace carrier	79
Fig. 42	Furnace partially pressed out of the Zeeman magnet	80
Fig. 43	View of the furnace with radiation sensor module from below	81
Fig. 44	Furnace tools.....	81
Fig. 45	Electrode, partially pushed out	82
Fig. 46	Electrode with insertion device, mounted on the jaw.....	82
Fig. 47	Furnace shroud, partly pressed out.....	83
Fig. 48	Furnace shroud ready for insertion.....	84
Fig. 49	Window "Autosampler / Function tests" in the ASpect LS software ...	87
Fig. 50	Dosing tube at the AS-GF	87
Fig. 51	Dosing unit at AS-GF and AS-FD.....	89

1 Basic information

1.1 Intended use

The atomic absorption spectrometer ZEEnit 650 P is a compact spectrometer with transversely heated graphite tube atomizer with Zeeman background correction at the furnace and additionally with Deuterium background correction. The ZEEnit 650 P is not only designed for the HydrEA technique as coupling with the graphite furnace, but also for the hydride technique. When the graphite furnace is extracted, it has a defined support position for the cell unit. For the hydride technique and the HydrEA technique, there are hydride systems available as accessories for batch and continuous operation. The graphite furnace is designed for direct analysis of solid samples in combination with the manual or automatic solid autosampler.

Zeeman graphite furnace

For the Zeeman graphite furnace, there are available

- An IC tube with a capacity of 50 μ l
- A patented IC tube with 1-Pin platform with a capacity of 40 μ l
- A solid IC platform for solid samples up to 3 mg

Adaptive temperature control and regulation, as well as temperature correction via a pyrometric quotient method, ensure long-term stability and analytical correctness.

As an option a camera can be installed for observing the deposition of droplets in the graphite tube and the drying procedure.

The Zeeman graphite furnace can be taken out of the sample chamber for maintenance work to be carried out and then put back in again.

High degree of automation

The ZEEnit 650 P is a PC-controlled multi-element automatic machine for sequential determination of traces and ultra-traces of metals and semi-metals in liquid, solution and solid samples in routine analysis and for research purposes.

To satisfy the highest analysis expectations, all spectrometer settings are motor driven. With the autosamplers of the respective technique, the measurement of liquid, solution and solid samples can be carried out fully automated.

1.2 Notes on the manual

The following symbols for warnings and system messages are used in this manual:



Danger!

This symbol must be strictly observed to protect against personal injury.



Danger!

Electromagnetic dispersion fields.



Danger!

Forbidden for people with a heart pacemaker!



Danger!

Not to be operated by persons wearing (metal) chains etc. around the neck.



Danger!
Combustible materials!



Danger!
Danger of electric shock if touched!



Warning! Hot surface!
Touching the hot surface can cause burns.



Warning!
This symbol, coupled with the text "Warning", indicates potential danger for the operator.



Warning!
Emission of UV radiation!



Caution!
This symbol, coupled with the text "Note", must be observed to protect against damage to the device.



Note
This symbol must be observed to obtain correct measurement results.

The manual uses the following system:

- The numbering of the chapters and figures is consecutive.
- Each figure has its own caption.
- Working steps are numbered.
- Cross references to other sections are marked with an arrow (e.g., → "Notes on the manual" S.7)

2 Safety instructions

For your own safety and to ensure error-free and safe operation of the ZEEnit 650 P, please read this chapter carefully before using the appliance.

Comply with all safety instructions in the manual and pay careful attention to all messages and notes which are displayed on the screen by the control software.

2.1 Proper use

The ZEEnit 650 P may only be used for atomic absorption spectrometry in the techniques described in this manual. Any departure from the instructions for proper use may lead to warranty restrictions and reduced manufacturer liability in the case of damage.

If the safety instructions are not observed in handling the ZEEnit 650 P, this is taken to be a use which deviates from the intended purpose. Safety instructions are to be found especially on the equipment itself, in Section "Safety instructions" S.9 and in the description of the relevant working steps.

2.2 Summary of safety instructions



Local regulations!

Local safety regulations that apply to the use of this device (e.g., work protection regulations, accident prevention regulations, safety regulations) must be observed.

References to potential dangers in the manual do not replace the work protection regulations which must be observed.



Personnel!

The ZEEnit 650 P may only be operated by qualified personnel, who have received additional training for this type of work. Familiarization with the contents of this manual and the accompanying manuals of accessories and system components must be included in this training.

Any work on electrical equipment may only be carried out by qualified electricians.



Protection against explosion and fire

The ZEEnit 650 P may not be operated in an explosive environment.

No smoking is allowed in the operation area of the ZEEnit 650 P.



Installation and initial use

The device may only be assembled, installed and repaired by service engineers from Analytik Jena or by technical personnel authorized by Analytik Jena. Any unauthorized interference may place the operator in danger, may endanger the functional safety of the instrument and will limit warranty entitlements.



Safeguards

All ZEEnit 650 P safeguards must always be enabled, functioning and not bypassed.



Warning signs

Observe the warning signs on the device! (See Section "Warning signs on the " S.14.)



Switching off the device in the event of danger!

Switch off the ZEEnit 650 P using the mains switch on the right side wall. Disconnect the mains plug from the mains socket.

Make sure that the mains plug is readily accessible.

Switch off the installed components using the mains switch of the connected multiple adapter. Ensure that the multiple adapter is positioned in such a way to allow quick access.

Caution! For the PC there is a risk of data loss and damage to the operating system!



Electric shock!

The ZEEnit 650 P is supplied with electrical voltage. Life-threatening electrical voltages may occur in various parts of the system!

The mains plug may only be connected to a proper CEE power socket to ensure that the device meets protection class I (ground connector). It may only be connected to power sources whose nominal voltage is the same as that on the nameplate of the equipment. The protective effect must not be invalidated by the use of an extension line which does not have a protective conductor (→ Section "Energy supply" S.27).

The **auxiliary components** have to be connected to the **multiple adapter** supplied. **Observe the maximum allowable drain current** when connecting your own components to the multiple adapter (see Section "Energy supply" S.27).

The ZEEnit 650 P must be switched off before carrying out any electrical work and the **mains plug must be disconnected**. Safe disconnection from the mains can only be achieved by pulling out the mains plug. **Power is still supplied to the multiple adapter, even when the ZEEnit 650 P is switched off** at the mains switch on the right side wall. The multiple adapter socket connection of the ZEEnit 650 P **is protected by a fuse in both wires**, both in the L-line (phase) and in the N-line (neutral). This can mean in the case of a fault that connected components are supplied with voltage via the L-line, but no current can flow through the N-line, i.e., without a more thorough check, the connected devices appear to be voltage-free, which is not true.

The removal of the rear panel of the device may only be carried out by the customer service of Analytik Jena and specially authorized technicians.



Short circuit caused by wearing jewelry

There is a risk of a short circuit occurring between the two parts of the furnace, or between a furnace part and the console. Short-circuited jewelry heats up quickly and can cause burns.

No (metallic) jewelry (especially around the neck) may be worn during working on and with the ZEEnit 650 P. Danger of causing a short circuit of the electrically heated graphite tube.



Electromagnetic dispersion fields

Electromagnetic dispersion fields with flux densities of $\leq 100\mu\text{T}$ occur in the vicinity of the sample chamber due to the bipolar Zeeman magnetic field with maximum flux densities between 0.5 and 1.0 Tesla and also due to the heating of the graphite tube.



When operating the ZEEnit 650 P, people with pace makers are not permitted in close range.

Do not place magnetic data storage devices near the sample chamber.



Operating substances, dangerous substances

The operator is responsible for the selection of substances used in the process as well as for their safe handling. This is particularly important for radioactive, infectious, poisonous, corrosive, combustible, explosive and otherwise dangerous substances.

When handling dangerous substances, local safety instructions and guidelines must be observed.

Warnings on the labels must be always observed.

Only use clearly marked containers as well as protective goggles and rubber gloves.

The ZEEnit 650 P may only be operated under an **active laboratory exhaust hood** (ozone, combustion gases given off by the sample, poisonous and combustible by-products from sample preparation processes).

Cleaning with hydrofluoric acid must be carried out in an **exhaust chamber**.

When handling hydrofluoric acid, **rubber aprons, gloves and face masks** must be worn.

Biological samples have to be handled according to local guidelines regarding the handling of infectious material.

Warning! Sodium borohydride (NaBH_4) is strongly corrosive, hygroscopic and, in solution, extremely aggressive. Avoid dripping and spilling of reduction agent.

The operator is responsible for ensuring that **waste materials**, e.g. drained cooling agent, are disposed off in an environmentally responsible manner and according to local regulations.

List of dangerous organic solvents

Methyl isobutyl ketone (MIBK)	Highly volatile, noxious-smelling
Toluol	Danger to health
Kerosene	Flammable, low vapor pressure
Methanol, ethanol, propanol	Combustible, partly dangerous to health
Tetrahydrofuran (THF)	Highly volatile, easily ignited, dissolves polyethylene and polystyrenel

This list is in so far incomplete that other solvents could also come into consideration for use in the AAS ZEEnit 650 P. In cases of uncertainty about an unnamed fluid, this may only be used when the manufacturer has confirmed that there is no danger to safety.

Cleaning and decontamination measures

The operator is responsible for carrying out suitable decontamination should the device be contaminated externally or internally with dangerous substances.

Spots, drops or larger spillages should be removed and cleaned using an absorbent material such as cotton wool, laboratory wiping cloths or cellulose. The affected areas are then to be wiped with an **Incidin Plus solution**.

Before another cleaning or decontamination procedure is used as that prescribed by the manufacturer, the user shall check with the manufacturer that the intended procedure will not damage the device.



UV radiation and danger of dazzling

Protect your eyes!

Never look directly at radiation from HCL, D2HCL, the heated graphite tube or the burner flame without UV protection glasses.

Graphite tube radiation > 1000 °C causes UV burns on unprotected skin.



Ozone

The UV radiation of the hollow cathode lamp (HCL, D2HCL) and of the graphite furnace at temperatures of over 2000°C leads to an interaction with the surrounding air to form toxic concentrations of ozone exceeding the permissible limit.

The ZEEnit 650 P may only be operated with an active exhaust unit.



Sound level

In Zeeman operation with magnetic field strengths of 1.0 Tesla, the sound level can be as high as 75 dBA.



Operating pressurized gas cylinders and gas plants

Inert gas and auxiliary gas is taken from pressurized gas cylinders or local gas plants.

For pressurized gas cylinder or gas plant operation, the safety instructions and guidelines which are valid at the operating location must be strictly complied with.

High pressure tubing and pressure regulators may only be used for the assigned gases.

The operator must carry out weekly safety checks for leaks on all gas supplies and connectors up to as far as the device itself. Possible pressure drops in closed, pressurized systems and piping must be determined. Leaks must be localized and repaired immediately.

After changing the gas cylinder, thoroughly ventilate the cylinder location.



High temperatures

High temperatures arise during graphite furnace operation.

Observe the required cooling times!

Do not touch the hot components during, or directly after, a measurement.

Undertake maintenance work and change components only after an adequate cooling period: graphite furnace, cells, lamps.

Keep all combustible material away from the device.



Ventilation

Ensure that the ventilation fittings for the ZEEnit 650 P and its auxiliary devices are

kept free of obstruction. Covered vents or ventilation slits may cause the device to break down or may cause damage to it.

Comply with the minimum distance requirements to walls and neighboring installations of 150 mm for the mobile cooling unit.



Cleaning and maintenance

Service, maintenance and repair work on the AAS ZEEnit 650 P may only be carried out by service engineers from Analytik Jena or by technicians authorized by the manufacturer. Exceptions to this are described in Section "

Care and maintenance" S. 73. If these requirements are not complied with, there is a serious risk of misalignment or damage to the device.

The exterior of the ZEEnit 650 P may only be cleaned with a damp, not dripping, cloth.

For cleaning the sample chamber of the ZEEnit 650 P, the operator must observe the appropriate safety precautions - particular note must be taken of contaminated and infectious materials.



Graphite tube technique

Use only the inert gas specified in the manual for the graphite tube technique.

Do not look into the graphite tube opening without wearing protective goggles.

Sputtering sample substances and hot graphite particles may cause eye and face injuries.



Replacing graphite tubes, replacement parts

Only use replacement parts from Analytik Jena.

The graphite tubes of the ZEEnit 650 P are manufactured specifically and may only be ordered from Analytik Jena. Do not use any other graphite tubes. Other graphite tubes can damage the ZEEnit 650 P.



Sensitive electronics

Always electrically connect and disconnect components to the ZEEnit 650 P when they are switched off.

This also applies when electrically connecting components with one another.

2.3 Warning signs on the ZEEnit 650 P

Observe the warning signs on the device! The following warning signs are displayed on the ZEEnit 650 P:



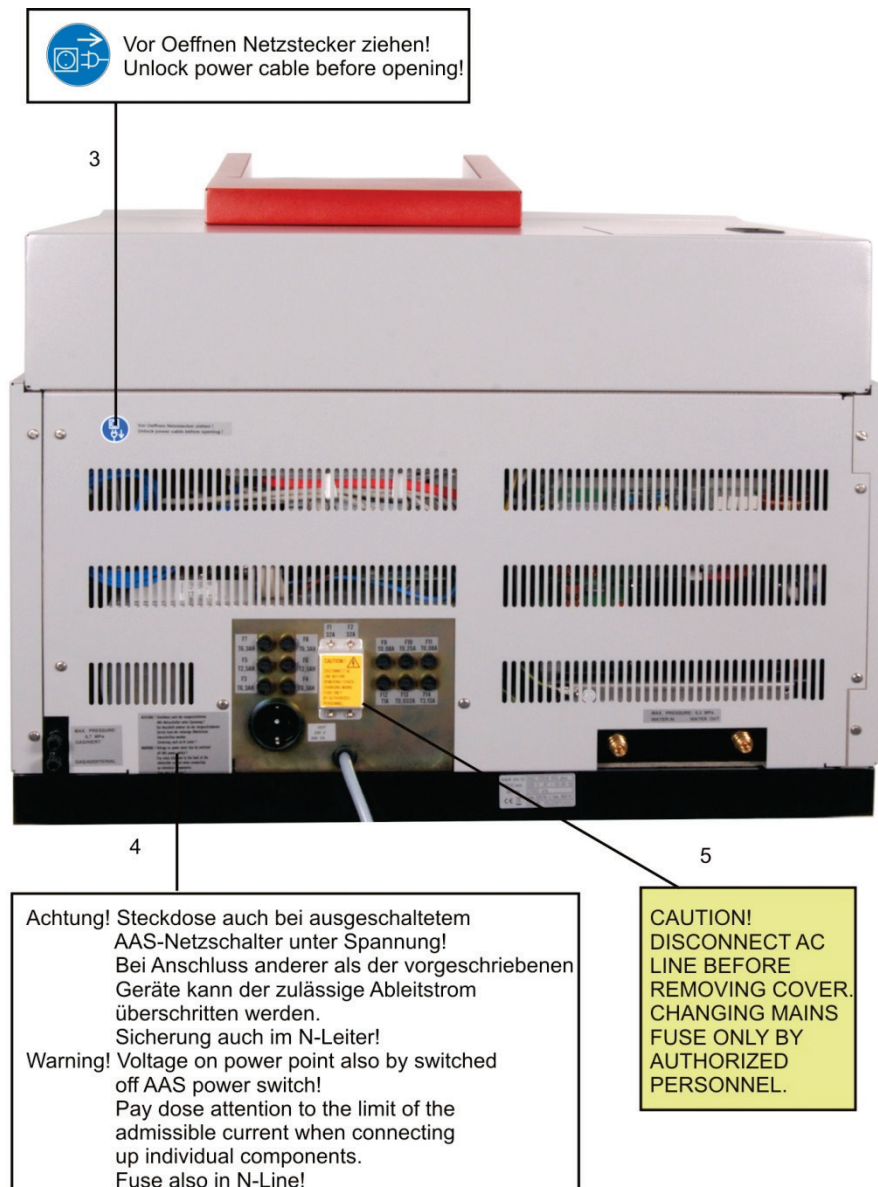

- 1 Warning sign on the inside of the door to the lamp chamber
- 2 Warning sign in the sample chamber of the graphite furnace
- 3 Warning sign on the rear of the ZEEnit 650 P
- 4 Warning sign next to the connection socket
- 5 Warning sign on the mains fuse cover

Fig. 1 Warning signs on the ZEEnit 650 P

3 Specifications

3.1 Technical data

3.1.1 Data for the ZEEnit 650 P

Techniques

Graphite tube technique for solution and solid samples in single-beam operation with Zeeman or deuterium background correction

Hydride and mercury cold vapor technique in single-beam operation with deuterium background correction.

HydrEA technique in single-beam operation with deuterium background correction.

Background correction

Zeeman background correction

Transversally arranged and microprocessor-modulated, bipolar magnetic field with 3 correction modes:

- 2-field technique: The maximum field value can be selected in steps between 0.5 and 1 Tesla.
- 3-field technique: The field values can be selected in steps between 0.1 and 0.95 Tesla.
- Dynamic mode

Deuterium background correction with current-controlled D2HCL

Photometer

Single-beam arrangement with dual-beam base line stability

High light yield

Quartz-improved mirror optics

Wide-range photomultiplier, R928, 9-stage

Quartz polarizer with anti-reflex coating and UV-optimized transmission, can be moved from the path of the beam

Monochromator

Assembly	Optimized Czerny-Turner layout with flat hologrid, automatic wavelength and slit width setting
Wavelength range	185 to 900 nm
Slit width	0.2 nm; 0.5 nm; 0.8 nm; 1.2 nm

Lamp turret for HCL

PC-controlled 8-lamp turret for fully automated operation with a write/read unit (RFID) for the use of coded lamps.

Hollow cathode lamps HCL, coded

Lamp type: Glow discharge lamps for 68 elements with line radiation in the UV/VIS range

Lamp current	2 to 20 mA
--------------	------------

Mode	Electrical timing - in Zeeman operation 2-field and 3-field modes 200 Hz - in D2 graphite furnace mode and hydride mode 100 Hz - in flame mode 50 Hz
Power supply	2 power packs, electrically stabilized - for active lamps - for preheating

Super-hollow cathode lamps, coded

Lamp type: Glow discharge lamps with additional discharge. Line radiation in the UV/VIS range

Lamp current	2 to 20 mA
Boost current	0 to 50 mA
Mode	Electrical timing - in Zeeman operation 2-field and 3-field modes 200 Hz - in D2 graphite furnace mode and hydride mode 100 Hz - in flame mode 50 Hz

Deuterium hollow cathode lamp D2HCL

Lamp type: Glow discharge lamp with continuum radiation in the UV range

Lamp current	5 to 35 mA
Mode	Electrical timing - in graphite furnace mode and hydride mode 100 Hz - in flame mode 50 Hz

Analytical working modes in absorption

Total absorption
Specific and unspecific absorption

Display modes

Absorbance	-0.01 to 3.00
Concentration	Value range: 5 characters (0.001 to 99999), unit freely selectable
Standard energy	0% to 100%

Measurement value processing

Measurement frequency (single value order)	- in Zeeman operation 2-field mode 150 Hz - in Zeeman operation 3-field mode 200 Hz - in D2 graphite furnace mode and hydride- mode 100 Hz (corrected single values)
Signal detection	Microprocessor measurement acquisition system optimized for signal/noise ratio on the basis of correlated double sampling technique (CDS technique)

Specifications

Signal evaluation, integration type	Mean value Mean value (repeated) Maximum value: Maximum value of the absorbance Integral value: Time-integrated absorbance
Integration time	0.1 to 600 s
Autozero (AZ measuring time)	0.1 to 600 s
Delay	0 to 600 s
Energy measuring time	0.3 s
Smoothing	Running average: over 0, 2, 4, 8, 12, 16 or 20 measuring points Weighted average: over 0, 5, 11, 19 or 25 measuring points (Method of the smallest error squared, according to Golay-Savitzky)
Type of measurement value displays	Absorbance, concentration
Number of digits	3, 4 or 5
Units of concentration	mg/L, µg/mL, ng/mL, µg/L, ng/L or user defined
Results display window	Alphanumerical values Bar chart of integrated values (bar graph) Time run of the single peaks Overlapping peaks Graphical peak overview
Special window	Temperature-time program (furnace program) Optimization of the furnace program Mercury/hydride report Concentration values in the reference curve Peak plots with variable integration limits
QC window (Quality Check)	QC blank – Blank QC chart QC control samples – Blank QC chart – Recovery chart QC duplicate measurement sample/matrix – Differences chart (trend chart) – Range chart (range chart) – Precision chart (SD chart) QC spike sample – Percentage recovery chart
Statistical methods	Sigma statistics – Mean value with standard deviation (SD) and relative standard deviation (RSD) Median statistics – Media value with range (R) and relative range (R%)
Confidence interval	Can be selected: Absolute, relative or none Selectable confidence interval: 68.3% (1 σ) 90% (1.6 σ)

	95.4% (2 σ) 99% (2.6 σ) 99.7% (3 σ) 99.9% (3.6 σ)
--	--

Calibration

Calibration techniques	Standard calibration (recalibration) Bracketing calibration Standard addition (for solid techniques 3D display) Addition calibration
Fit reference curve	Linear, variable weighting functions Non-linear, variable weighting functions
Number of standards	1 to 30
Number of addition concentrations	1 to 30
Recalibration	Two-point recalibration with display of the recalibration factor

Power supply

Supply voltage	200 / 220 / 240V \pm 10% factory adjustable
Frequency	50/60 Hz
Mains fuse installation in the building	Safety fuse 35 A, slow blow No automatic fuse devices!
Typical average power consumption	2100 VA
Maximum current consumption	52 A for a period of 8 s or 85 A for 1 s
Output socket	Like input socket (200/220/240V \pm 10%, 50/60Hz) For connection of accessories: PC, compressor, hydride system
Overvoltage category	II according to DIN EN 61010-1
Degree of contamination	2 according to DIN EN 61010-1
Safety class	I
Safety type	IP 20

Instrument fuses

Power supply fuse

The power supply fuses may only be changed by service engineers from Analytik Jena or by technical personnel authorized by Analytik Jena.

gL-instrument fuse fittings (10×38 mm²) according to 60947-3.

Fuse number	Type	Protected circuit
F1 / F2	32 A/T	Power supply

Instrument fuse fittings (5×20 mm²) according to IEC 60127.

Fuse number	Type	Protected circuit
F3 / F4	T 6.3 A/H	Socket for external accessories
F5 / F6	T 2.5 A/H	Transformer, primary side, NTL
F7 / F8	T 6.3 A/H	Power supply of the magnet
F9	T 0.08 A	D2-HCL
F10	T 0.25 A	HCLs
F11	T 0.08 A	Boost current
F12	T 1 A	Heating for boost current
F13	T 0.032 A	Analog
F 14	T 3.15	Filament

Internal fuses

Fuse number	Type	Protected circuit
F1 internal	TR5-T 100 mA	Zeeman furnace measuring lead
F1 internal MagPS	FF 4 A/H	Power supply of the magnet

Environmental conditions

according to DIN ISO 90022-2:2003 / 01

Corrosion protection	The device is corrosion-proof for the samples used in the analysis.
Working temperature	+10°C to +40°C
Humidity during operation	Max. 93 % at +40°C
Storage temperature (use drying agent)	- 40°C to +70°C

Dimensions and weights

Mass	170 kg
Dimensions (W x H x D):	790 mm × 645 mm × 735 mm
Transport of device	Only possible using the corresponding carrying handles which must be securely screwed into place

3.1.2 Minimum requirements of the ASpect LS software

Computer (minimum requirements)	Resolution 1280x1024 pixels or higher Mouse / trackball 2 x USB-2.0 interfaces
Operating system	Windows 8.1 or 10 (32 bit or 64 bit)

3.1.3 Data for the graphite tube technique

Graphite furnace

Type of sample	Liquid Solid
Type of tube	IC tube (wall atomization) IC tube with 1-PIN platform IC tube solid All tube types are pyro-coated.
Volume	Max. 50 µL
Temperature setting	Temperature can be set between room temperature and 3000°C, in steps of 1°C
Temperature-time programming (furnace program)	Up to 20 steps can be freely programmed within determined limits, 0 to 999 s/step, in intervals of 1 s Temperature increase (ramp): 1°C/s to 3000°C/s linear and maximum non-linear ramps (Full Power FP / No Power NP) Control of inert gas and auxiliary gas Inserting injection and enrichment steps Determining the starting point for autozero and integration
Cooling water	Min. 2.5 L/min, sediment-free 20°C to 40°C
Inert gas	Argon 4.8 and superior Permitted components: Oxygen ≤ 3 ppm Nitrogen ≤ 10 ppm Hydrocarbons ≤ 0.5 ppm Humidity ≤ 5 ppm Consumption Max. 2 L/min (depending on temperature-time program) Inlet pressure: 6 to 7 bar
Safety circuits ensuring protection against	If transformer for furnace heating is overheated If the magnet coils are overheated If the graphite tube is broken If the graphite furnace is overheated If the graphite furnace is open during operation If there is a shortage of cooling water If the inlet pressure of the inert gas is too small If malfunctions occur in the magnetic control system and the supply system

Autosampler AS-GF

Autosampler with dilution function, completely PC controlled

Sample tray	108 positions
Sample cups	100 pieces, 1.5 mL
Special cups	8 pieces, 5 mL
Pipetter volume	1 to 50 µL
Wash volume	0.5 mL, number of wash cycles can be selected
Program methods	Standard Modifier Dilution Addition Automatic enrichment
Mass	7.2 kg

Mobile cooling unit KM 5

Air cooler with thermostat; CFC free

Tank capacity	5 L
Capacity	3 L/min

Accessories for direct solid analysis

SSA 600	Solid autosampler for automatic operation
SSA 6	Solid autosampler for manual operation

3.1.4 Data on autosamplers for hydride and HydrEA techniques

Autosampler AS-F

Autosampler without dilution function, completely PC-controlled

Sample tray 139/ 15	
Sample cups	129 pieces, 15 mL
Special cups	10 pieces, 50 mL
Sample tray 54/ 50	
Sample cups	54 pieces, 50 mL
Power supply	Via AAS basic instrument
Wash bottle	2 L
Mass	6.5 kg

Autosampler AS-FD

Autosampler with dilution function, completely PC-controlled

Sample tray 139/ 15	
Sample cups	129 pieces, 15 mL
Special cups	10 pieces, 50 mL
Sample tray 54/ 50	
Sample cups	54 pieces, 50 mL
Dosing unit in the Fluidics module	5 mL

Power supply	Via AAS basic instrument
Wash bottle	2 L
Bottle for diluent	2 L
Mass (total)	10.0 kg
Autosampler	6.5 kg
Fluidics module	3.5 kg

Mercury/hydride systems

HS 60 modular, HS 55 modular, HS 50

Hydride- and HydrEA-techniques

See the instruction manual for mercury/hydride systems

3.2 Guidelines and standards

Safety class and safety type

The ZEEnit 650 P belongs to safety class I.
The casing has safety type IP 20.

Device safety

The ZEEnit 650 P conforms to the safety standards

- DIN EN 61010-1 (VDE 0411T.1; IEC 61010-1)
- DIN EN 61010-2-061 (IEC 61010-2-061)

EMC compatibility

The ZEEnit 650 P has been tested for radio interference elimination and interference immunity and fulfills the requirements stipulated by

- DIN EN 61326

Environmental compatibility

The ZEEnit 650 P has been tested for environmental compatibility and fulfills the requirements stipulated by

- DIN ISO 9022-3:2000
- DIN ISO 9022-32-03-0
- DIN ISO 9022-2:2003/01

EU directives

The ZEEnit 650 P is built and tested according to standards that fulfill the requirements stipulated by the EU directives 2014/35/EU and 2014/30/EU. Each device leaves the manufacturer in a pristine and technically safe state. To maintain this condition and to ensure safe operation, the operator must strictly observe the safety and operating instructions contained in this manual. For accessories which have also been supplied, and system components from other manufacturers, their operating instructions should be referred to.

4 Installation conditions



The device may only be assembled, installed and repaired by service engineers from Analytik Jena or by technical personnel authorized by Analytik Jena. Any unauthorized interference limits warranty entitlements.

When setting up assistance is needed for part of the time. The service engineer will test the device and document the test in the test report of the ZEEnit 650 P.

The operator is responsible for everything which is not included in the original delivery, but which is necessary for operation of the ZEEnit 650 P. Operation of the ZEEnit 650 P demands certain local and system-specific requirements:

- Suitable place for assembly
- Space
- Environmental conditions
- Supply of inert gas
- Exhaust unit
- Mains connection



Caution!

Pay attention to the safety instructions in Chapter "Summary of safety instructions" S.9.

Observe work protection regulations. Warnings regarding potential dangers do not replace valid work protection regulations!

Possible dangers when working with the ZEEnit 650 P are:

- Danger of burning by hot furnace parts
- Danger from electric current
- Danger of UV radiation
- Danger of ozone or nitride oxide formation
- Danger when handling pressure cylinders
- Danger from toxic and chemically aggressive substances
- Danger due to strong magnetic field

4.1 Environmental conditions

Do not set up the ZEEnit 650 P directly beside a door or a window. The work space of the ZEEnit 650 P should be free of draft, dust, corrosive vapor and also vibrations.

Do not set up the ZEEnit 650 P close to any electromagnetic source.

Avoid direct sunlight and heater radiation on the ZEEnit 650 P. In extreme cases, provide acclimatized conditions in the room.

A separate room is recommended for preparing samples and storing wet-chemical materials.

There is a no smoking policy in the room where the ZEEnit 650 P is operated.

Temperature range during operation	+10°C to +35°C
Temperature range during storage and transport	-40°C to +70°C , use drying agent
Humidity during operation	Max. 90% at +30°C
Humidity during storage	10% to 30%, use drying agent

4.2 Space requirement and weight

Minimum size of work tables:

- For the base device on its own: 800 mm × 700 mm, select the height according to ergonomic requirements
- For the base device, monitor and printer: 1600 mm x 700 mm

Carrying capacity of work table: at least 210 kg

Additional space on the ground for mobile cooling unit KM 5 and, if necessary, the PC

Table surfaces: wipe, scrape and corrosion resistant, not allowed to absorb moisture

Set up the work table in such a way to allow easy access from all sides. For unimpeded cooling air circulation and effective cooling, the surfaces of the casing sides of the mobile cooling unit require a minimum distance of 15 cm from the nearest object.

Components	Width [mm]	Height [mm]	Depth [mm]	Weight [kg]
On the work table				
ZEEnit 650 P	790	645	735	170
AS-GF	250	550	380	7,2
AS-F	340	350	460	6,5
AS-FD				
Autosampler	340	350	460	6,5
Fluidics module	360	310	165	3,5
HS 60 modular	360	370	240	14
HS 55 modular	360	370	240	14
HS 50	270	210	190	2
SSA 6	260	90	260	1
SSA 600	300	370	500	10
Under the work table				
Mobile cooling unit KM 5	260	660	560	32

Table 4-1 Measurements and weights of the components of the ZEEnit 650 P

4.3 Energy supply



Observe the mains connection!

During electrical installation, observe the VDE (German Association for Electrical Engineers) electrotechnical guidelines and local regulation requirements!

The mains supply must be correctly grounded.

Do not use an adapter in the mains cabling.

Do not use an automatic fuse device.

The ZEEnit 650 P is operated on single-phase alternating current. The current load can reach 85 A for a short period (1 s) during maximum heating. The mains voltage at the ZEEnit 650 P should not decrease by more than 6% during this period. For any deviation from these values, please contact Analytik Jena. Appropriate accessories can be supplied.

Optimum device function strongly depends on a correct mains connection with adequate cable cross-section. The mains connection shall be protected on the input (building) side with a 35 A slow-blow fuse and must be installed prior to delivery of the ZEEnit 650 P near the assembly point. The instrument cable is 3 m long. The CEE surface socket (2 pole + E Blue 5UR 3 206-2 220/32, Siemens) is supplied according to the terms of delivery.

The mains plug is used to isolate the device from the power supply. Therefore make sure that the mains plug is readily accessible.

All other components of the ZEEnit 650 P (e.g., PC, printer etc.) are connected via the 5-way socket strip supplied, which is plugged into the rear of the ZEEnit 650 P, and connected to the same phase as the base device itself. If you use your own PC-printer configuration, and if it is connected via the 5-way multiple adapter, observe the limit of the permitted line current (a total of 5 mA with auxiliary devices). To avoid sudden voltage fluctuations, do not connect the ZEEnit 650 P to the same electrical circuit as other power-intensive devices.

Switching on conditions

Voltage	200/220/240 V \pm 10% factory adjustable
Frequency	50/60Hz or different if specified in conditions and terms of supply
Typical average power consumption	2100 VA
Maximum current consumption	85 A over a 1-sec period or 52 A over 8 sec
Fuse provided (mains side)	35 A, safety fuse, slow blow, single phased Do not use automatic fuse devices!
Power consumption of the hydride system	700 VA while heating the cell 400 VA in continuous operation

4.4 Gas supply / gases in the graphite tube technique



Caution!

The operator must ensure that the connector type used on the outlet side of the gas pressure controller is adequate for the applicable national requirements. The operator must carry out the necessary safety leakage tests weekly on all gas supplies up as far as the device. For this, possible pressure losses from closed systems and lines under pressure are to be determined. Any leaks must be localized and corrected immediately.

The required inert gas is used to protect the graphite components of the atomizer, which are subjected to extreme temperatures. The inert gas is also used as a means of transport for the pyrolysis components accrued during the analysis. The purity of the inert gas is extremely important for the analysis and for the lifetime of the graphite tube.

By the introduction of an auxiliary gas (in addition to the inert gas and not instead of it) during the pyrolysis step (e.g., air or oxygen), the ashing of the sample, i.e., the removal of the matrix components, can be accelerated. The auxiliary gas is fed in through the "Gas Additional" connection on the rear of the device.

The gas pressure at the spectrometer must be between 6 and 7 bar.



Caution!

If the inert gas is supplied by pressure cylinders, these must be secured to the wall in an upright position with cylinder mounts outside the laboratory space.

The standard tube length is 5 m. If other tube lengths are preferred, please contact the customer service department at Analytik Jena.

Recommended inert gas	Inlet pressure	Consumption
Recommended for graphite tube operation: Argon 4.8 or superior Permitted components: Oxygen ≤ 3 ppm Nitrogen ≤ 10 ppm Hydrocarbons ≤ 0.5 ppm Humidity ≤ 5 ppm	6 - 7 bar	Max. 2 L/min (depending on the temperature-time program)

Table 4-2 Gases in the graphite tube technique

4.5 Exhaust unit



Switch on the exhaust unit during the use of the device!

Do not operate the ZEEnit 650 P without an exhaust unit!
Direct waste air to the atmosphere and avoid blockages!

Correct exhaust is only achieved with an exhaust hood that is installed directly above the sample chamber.

The exhaust unit should remove health-damaging residues as well as any ozone which has resulted. Ozone is caused by the reaction of air and UV radiation from the hollow cathode lamps and the graphite furnace at temperatures above 2000°C.

Use an exhaust unit made of heat and corrosion-proof material. The first 6 m of the exhaust unit should be made of metal.

Parameter	Properties
Material	V2A
Exhaust performance for graphite tube	Approx. 1 m ³ /min
Exhaust performance for graphite tube for samples with acid concentration > 5 %	Approx. 5 m ³ /min
Hood opening	Approx. 200 × 200 mm
Distance to the upper edge of the device	Approx. 200 to 300 mm
Tube diameter	Approx. 100 to 120 mm

Table 4-3 Exhaust unit requirements

4.6 Water cooling

The graphite furnace of the ZEEnit 650 P is cooled via a cooling system of the mobile cooling unit KM 5. Please observe the information provided in the instruction manual of the mobile cooling unit KM 5.

The KM 5 has to be filled with 5 L of softened water (not distilled water). The cooling water temperature can be set.

Parameter	Properties
Length of the water tubing	2.0 m
Length of the power cable	2.7 m
Length of the control cable	2.0 m
Water rate	0.3 Mpa; 3 L/min

To operate on a 60 Hz network, a special model of the mobile cooling unit KM 5 is necessary.

4.7 Device layout and space requirement

The ZEEnit 650 P is a compact device, conceived for mounting on a table. The space required is a function of all components needed for the measurement.

The PC with the monitor, the printer and the keyboard are arranged beside the base device. The PC and the printer can also be placed on a regular PC table.

The accessories for the graphite tube technique – autosampler AS-GF for dissolved samples or SSA 6 or SSA 600 for solid samples – are hung in the sample chamber.

The accessories for the mercury/hydride technique (HS 60 modular, HS 55 modular) with the associated autosamplers (AS-F, AS-FD with storage bottle or Fluidics module) are placed either to the right of the ZEEnit 650 P or on an additional table in front of the device.

The following are located on the floor near the device:

Installation conditions

- The receiving bottle for autosampler wash liquid and residue liquid of the mercury/hydride system
- The mobile cooling unit KM 5. The KM 5 must have at least 15 cm of free space at both sides to ensure optimum air circulation for the cooling air in-flow and outflow.

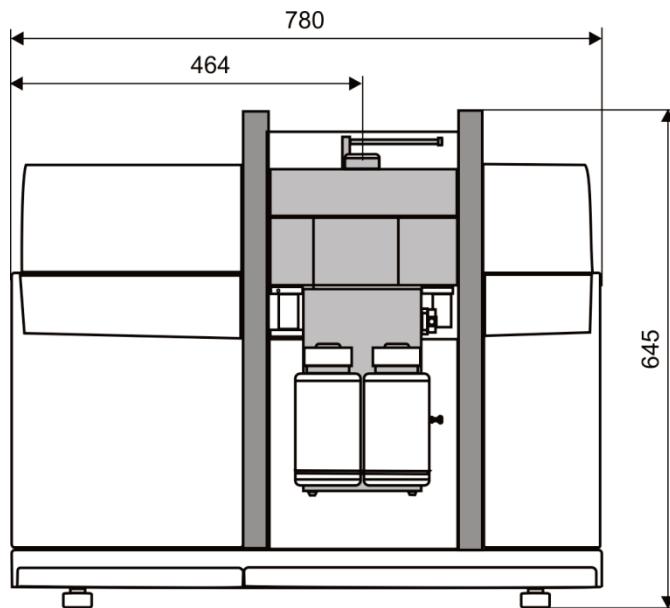

Fig. 2 Dimensions of the ZEEnit 650 P - front view

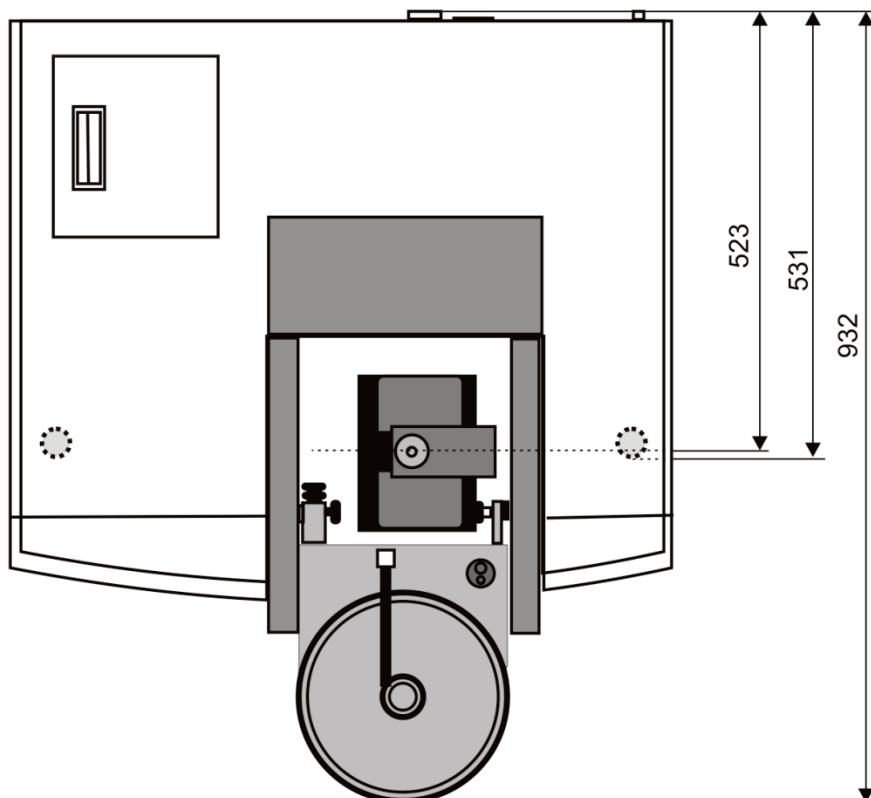

Fig. 3 Dimensions of the ZEEnit 650 P - top view

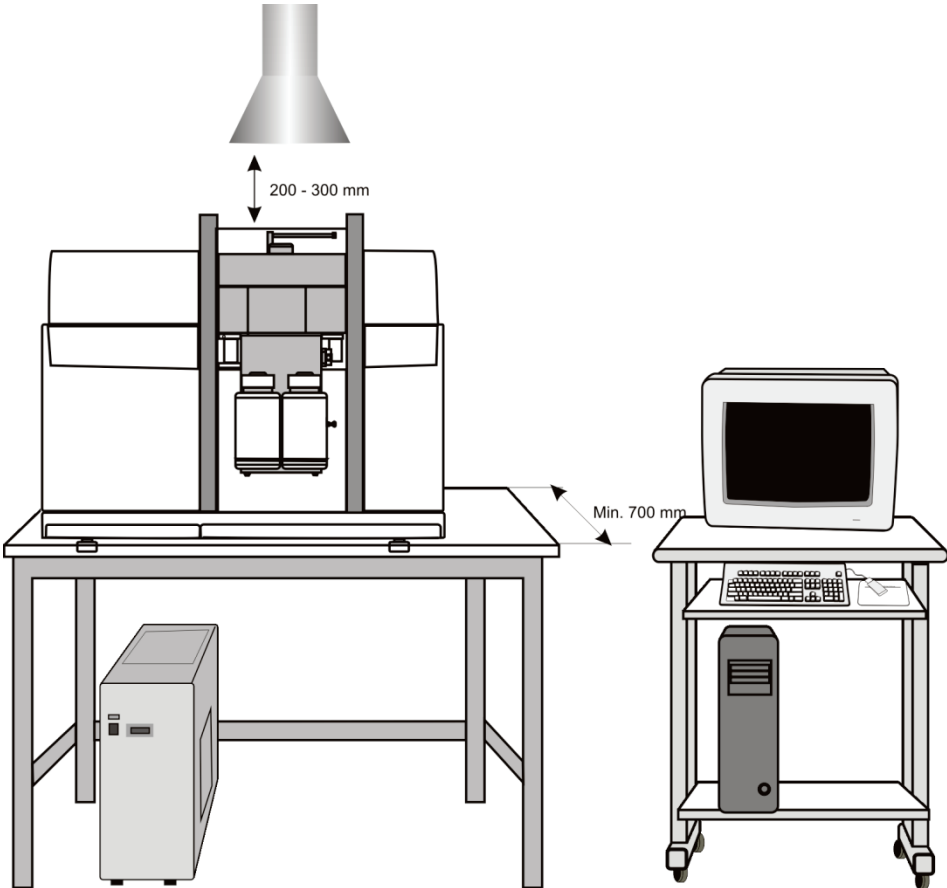

Fig. 4 Installation layout of the ZEEnit 650 P

5 Function and setup of the ZEEnit 650 P

5.1 Function of the ZEEnit 650 P

5.1.1 AAS techniques with the ZEEnit 650 P

The ZEEnit 650 P as a compact device includes, in combination with appropriate autosamplers and accessories, the following atomization techniques:

- Graphite tube technique for liquid samples
- Graphite tube technique for solid samples
- Hydride and mercury cold vapor technique
- HydrEA technique as coupling between hydride and graphite tube techniques



Fig. 5 ZEEnit 650 P

The core piece for the graphite tube mode is a graphite furnace with transversal magnetic field according to the inverse Zeeman principle. The graphite tube is transversely heated and set up in the vertical position.

The graphite furnace also has a horizontal sample insertion opening on the left side for direct solids analysis. With this, the time-consuming and contamination-susceptible sample information (the main source of error in solution analysis) is eliminated. For solids analysis, the manual solid autosampler SSA 6 or the automatic SSA 600 are available.

Hydride and HydrEA technique with the hydride systems of the new generation (HS 50, HS 55 modular, HS 60 modular) are the preferred processes for the detection-sensitive determination of the hydride-forming elements As, Bi, Sb, Se, Sn, Te and of Hg. The HydrEA technique (hydride technique with electrothermal atomization) is based on the fact that the metal hydride or mercury vapor is enriched on the

iridium-coated, preheated graphite tube and is atomized at 2100°C or 800°C respectively.

5.1.2 Optical principle

The ZEEnit 650 P is a single-beam device. On the left side the 8-lamp turret (8 in Fig. 6) is vertically arranged. The lamp turret accepts 1.5" hollow cathode lamps (HCL) as primary radiation source. On the left side there is in addition a deuterium hollow cathode lamp (D2HCL) (2 in Fig. 6) for the classical background compensation.

A movable mirror (1 in Fig. 6) alternately directs the radiation of the active primary HCL with the continuum radiation of the D2HCL into the spectrometer. Identical beam paths with the same beam distribution and density in the spatial angle used for both radiation sources make a background compensation up to an absorbance of 2.0 possible with the D2HCL.

For the graphite tube technique with Zeeman background correction, the ZEEnit 650 P works as a single-beam device, but with a movable crystal polarizer (6 in Fig. 6) in the sample radiation beam. The movable mirror for the HCL radiation is also moved to the 100% reflection position at the same time. The Zeeman-graphite tube furnace delivers radiation components with vertical and horizontal alignments. The crystal polarizer allows all radiation components with vertical alignment to pass without deflection, the radiation components with horizontal alignment are deflected so far that they fall completely on the slit mask next to the inlet slit even with the large slit width (0.6 mm). In all other techniques the crystal polarizer is located outside the radiation beam.

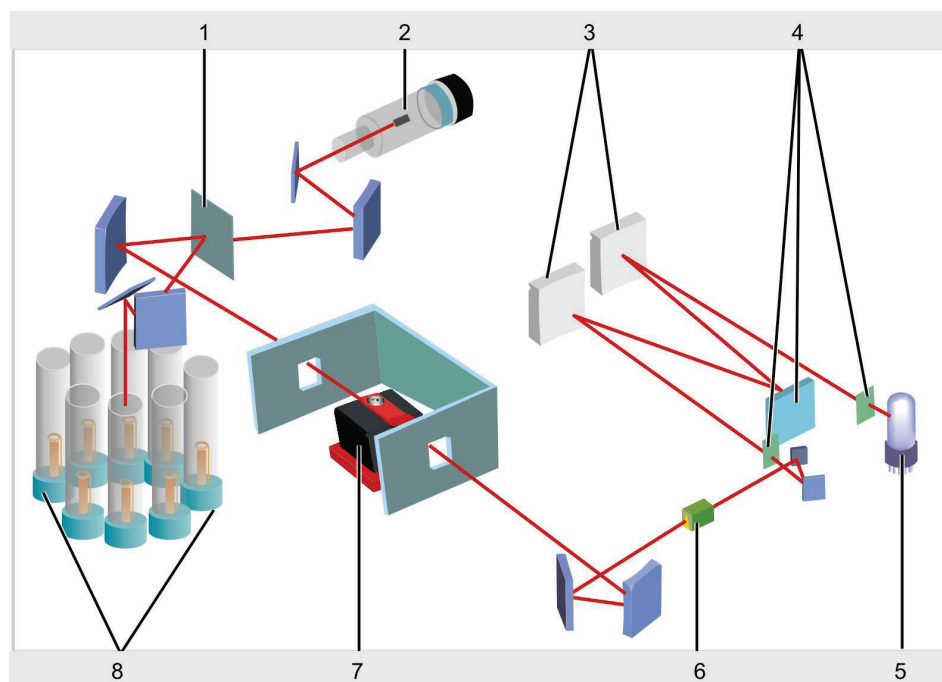

- | | |
|--|--|
| 01 Movable mirror | 05 Photomultiplier |
| 02 Deuterium hollow cathode lamp (D2HCL) | 06 Crystal polarizer |
| 03 Monochromator mirror | 07 Graphite furnace with graphite tube |
| 04 Entrance slit, grid, exit slit | 08 Lamp turret with 8 hollow cathode lamps |

Fig. 6 Optical schematic of the ZEEnit 650P

The sample beam is projected onto the entrance slit of a grid monochromator (3 and 4 in Fig. 6) that is fitted with the fixed band widths of 0.2 nm / 0.5 nm / 0.8 nm / 1.2 nm. The monochromator selects the resonance wavelengths assigned to the element. The wavelength setting of the monochromator takes place according to

the theoretical step number, referred to the Pb-line 405.8 nm as the initialization point and corrected by an amount which results from the device-specific wavelength interpolated function which is available as a polygon curve. 9 interpolation points are distributed equally over the wavelength range from the zero-th order up to 900 nm.

A peak-pick program is used to find the maximum of the particular line. The wavelength setting takes place using a wavelength drive driven by a step motor with a resolution of 0.005 nm per step.

A photomultiplier (5 in Fig. 6) at the exit of the monochromator measures, synchronously with the clocking of the light sources, the intensity of the impinging radiation.

5.1.3 Measurement principle

The element-specific absorption of the radiation of a hollow cathode lamp is measured by atoms in the base state. In this, the absorption signal is a measure for the concentration of the relevant element in the analyzed sample. The HCL delivers a line spectrum from which a suitable resonance line is decoupage by the monochromator.

Graphite tube technique with Zeeman background correction

Basic physical principle of the Zeeman effect

The Zeeman effect refers to the splitting of energy levels of electrons and thus the absorption levels under the influence of a strong magnetic field. If the magnetic field affects the atomic cloud of the sample in the atomizer (graphite furnace), this is an inverse Zeeman effect. A transverse Zeeman layout exists if the optical measurement beam (the observation) is arranged vertical to the magnetic field.

With a normal Zeeman effect, the absorption levels of the analyte atoms exposed to the magnetic field are split in a non-wavelength-shifted π component and two wavelength-shifted σ components σ^+ , σ^- .

With an abnormal Zeeman effect, more than one non-wavelength-shifted π component and more than two wavelength-shifted σ components occur.

The π and the σ components absorb different portions of the total HCL radiation that differ in terms of the direction of polarization:

The absorption capacity of the π component lies in the direction of the magnetic field vertical to the radiation direction in the meridional level (horizontal).

The absorption capacity of the σ components (σ^+ , σ^-) lies vertical to the magnetic field and to the radiation direction in the sagittal level (vertical).

The σ components have half the intensity of the π component and are shifted by an equal amount to the higher and lower wavelengths from the original wavelength.

Background correction principle according to Zeeman

A bipolar, horizontal alternating magnetic field with a frequency of 200 Hz is applied to the graphite furnace. In the alternating field, the absorption levels of the analyte atoms of the current analysis line are split up into the horizontally polarized σ components σ^+ , σ^- and the vertically polarized π component.

The downstream crystal polarizer allows all radiation components with vertical alignment to pass without deflection, the radiation components with horizontal alignment are sufficiently deflected that they do not impinge on the entrance slit.

In the measurement phase "Magnetic field off", the unaffected absorption signal is present; the spectrometer measures the sum of the specific and non-specific absorption. In the measurement phase "Magnetic field on", only the π component is recorded. It experiences, however, no element-specific absorption; only the weakening from the molecules and particles that show no Zeeman effect in the magnetic field. The non-specific absorption (background) is measured directly on the analysis line.

The difference between the signals of both measurement phases provides the element-specific absorption.

For both signals, the radiation source, the radiation beam, the measurement wavelength, polarization and reception channel are identical, i.e., a genuine double-beam effect is achieved using one beam (here the single-beam device). The quasi double-beam arrangement delivers an extremely good base line stability.

All other techniques with deuterium background correction

The continuum radiation of a D₂HCL is used for compensation of the background absorption. The radiation of the line radiator (primary HCL) with its extremely narrow base line (resonance line) is element-specific and weakened non-specifically by scattering. In doing this, the total radiation is recorded. The radiation of the D₂HCL is mainly weakened by the broad band, element-non-specific absorption, the minimum element-specific part can be neglected. The formation of the difference between the two signals gives the element-specific absorption.

The intensities of both radiation sources are automatically checked and adjusted if necessary.

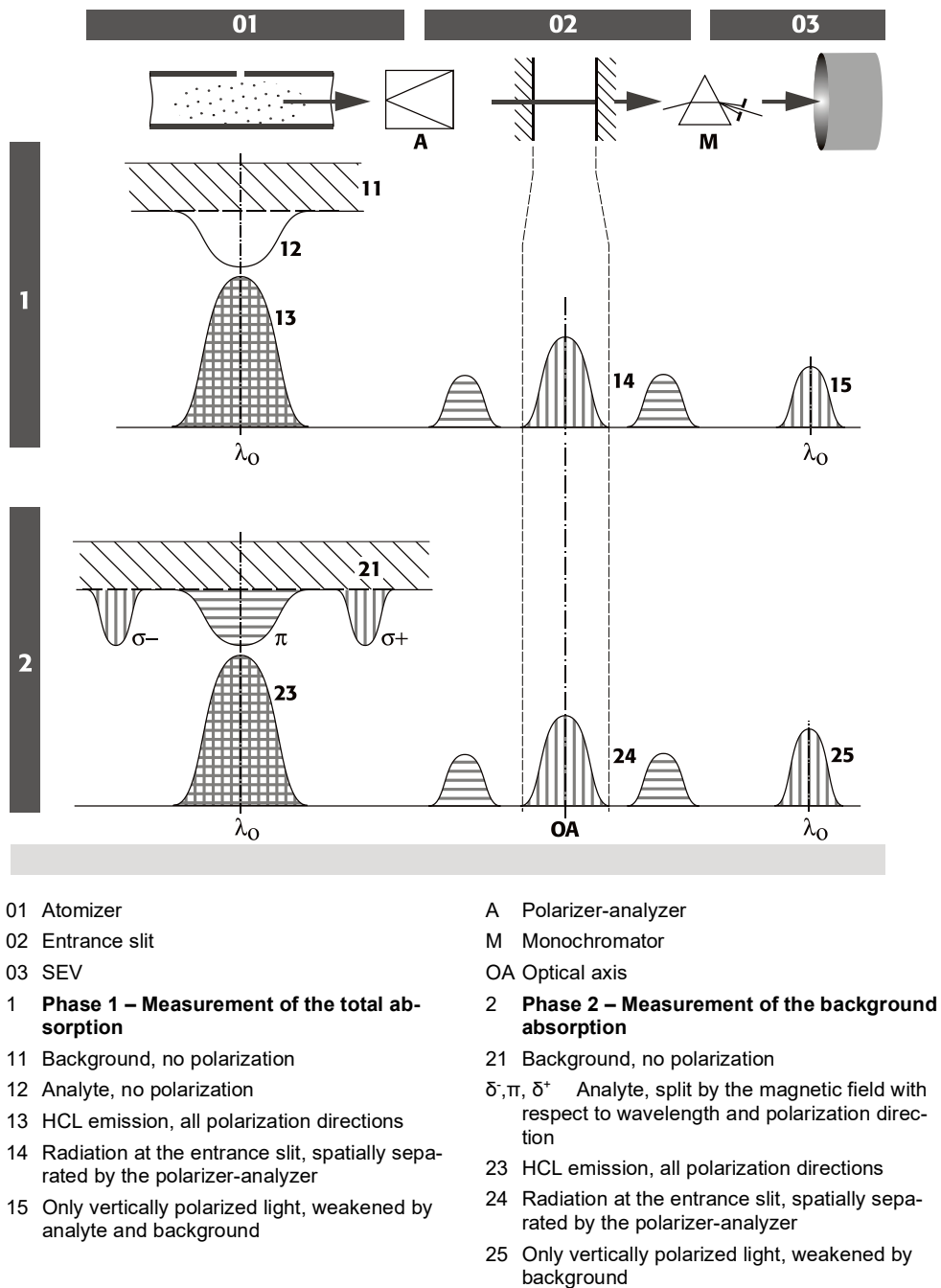

Fig. 7 Basic principle of transversal inverse Zeeman atomic absorption spectroscopy

5.2 Electrothermal atomizer with Zeeman magnet

The graphite furnace (electrothermal atomizer (EA)) is the core piece for working in EA mode and the HydrEA technique.

Graphite furnace characteristics

- Constant temperature ratios along the entire tube length ensured by the design of the transverse-heated graphite tube
- Realization of linear temperature-time runs according to a sensorless control model on the basis of saved thermoelectrical parameters and an adaptive control
- Protective gas flows, independent of each other and symmetrical to the furnace center, which ensure effective graphite tube and furnace window cleaning, and which also ensure fast and safe transport of the thermally disintegrated products of the sample for disposal
- Low consumption of protective gas, at the same time ensuring effective protection against interference with atmospheric oxygen.

The analytical advantage of the graphite tube technique in conjunction with the background compensator is the problem-free trace and ultra-trace analysis of real samples with a complex matrix

In the analysis, each sample runs through a furnace program (temperature-time program) with the aim of drying wet samples and of separating out any distorting incidental substances before atomization.

The furnace program runs in four basic steps:

- Drying the sample
- Thermal pretreatment, separating (ashing or pyrolysis of) distorting sample incidental substances (matrix)
- Atomizing the sample
- Cleaning the graphite tube and preparing for the next measurement.

The operator optimizes these basic steps for each analysis problem with the ASpect LS control software.

5.2.1 The Zeeman graphite furnace

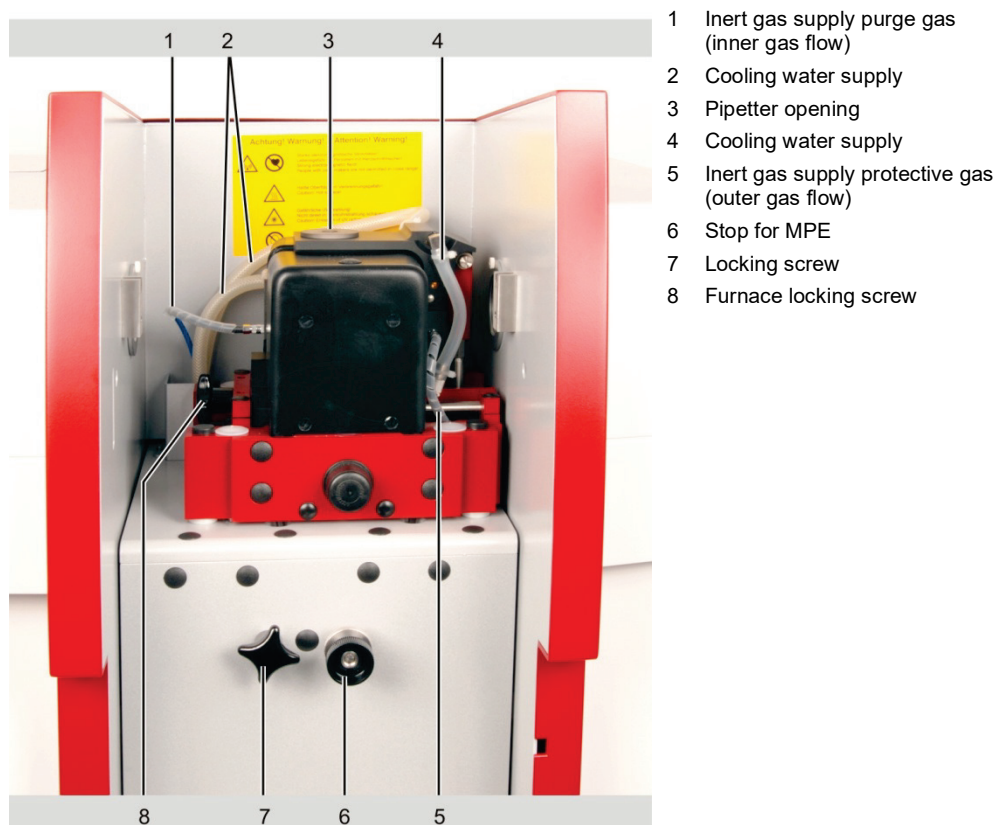
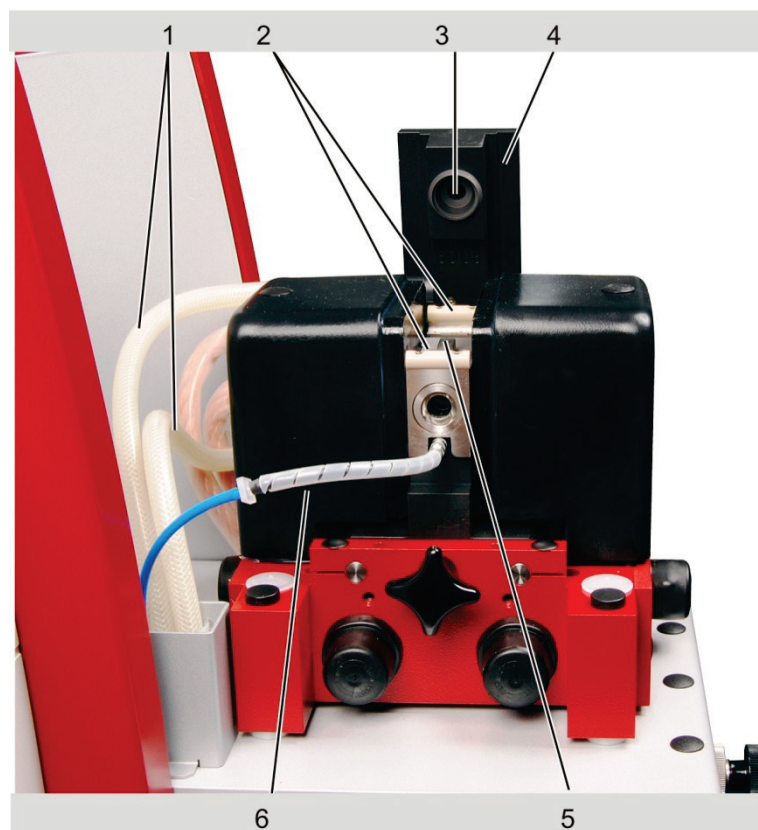

Fig. 8 Zeeman graphite furnace

The furnace consists of a fixed and a movable furnace part. Both furnace parts are water-cooled metal bodies, in which the ring-shaped graphite electrodes are to be found. The transversely heated graphite tube is pneumatically pushed against the graphite electrodes via its contact surfaces. There is another graphite component located between the metal bodies that support the electrodes, the furnace shroud. Together with the graphite electrodes it forms an enclosure around the graphite tube, which stabilizes the thermal radiation conditions of the graphite tube and also guarantees chemically inert conditions. When the movable furnace part is closed, the tube is pressed into the contacts, without coming into contact with the furnace shroud.

The graphite tube is hermetically sealed in a protective gas atmosphere by the two graphite electrodes and the furnace shroud. The furnace shroud is formed in a way to allow for beam passage, furnace windows and protective gas supply as well as guides for automatic alignment of the graphite tube when closing the furnace.

The upper horizontal metal block can be swiveled away to the right by a pneumatic cylinder. The lower, fixed metal block sits on a carrier module.



- | | | | |
|---|---------------------|---|-------------------------------------|
| 1 | Cooling water tubes | 4 | Upper metal block, open |
| 2 | Furnace window | 5 | Graphite tube in the furnace shroud |
| 3 | Upper electrode | 6 | Protective gas supply |

Fig. 9 Graphite furnace, open

The two metal blocks contain the connections required for current, protective gas and cooling water.

The vertical layout of the wings means that liquid samples are supplied by the autosampler AS-GF through the center of the upper wing.

Solid samples on a trough-shaped sample carrier (boat) can be supplied via the left horizontal furnace opening if the furnace windows are taken off and removed. The furnace shroud must be exchanged when changing between solution and solid forms of samples.

5.2.2 The Zeeman magnet

The Zeeman magnet consists of two similar U-shaped magnetic cores and two symmetrical coils. Both yoke halves are mechanically fixed and pressed against each other below the graphite tube furnace. At the top ends and directly behind the coils, the two yoke halves are beveled approximately to the cross-sectional area of the graphite furnace cavity. The polished end faces form the magnetic poles (pole shoes). In the area of the pole shoe, the graphite furnace is beveled to the extent that the pole shoes only have a clearance of 15 mm, which enables magnetic field strengths of 1.0 Tesla to be reached. The required magnetic field is homogeneously generated between the two pole shoes. Both poles shoes are shifted asymmetrically to the right (relative to the midpoint), and thus leave the necessary space for the solids autosampler.

5.2.3 Gas flows

The Zeeman graphite furnace houses the gas channels for the separate supply of the inner gas flow (purge gas) and the outer gas flow (protective gas).

The inner gas flow (purge gas) is directed into the furnace chamber through channels on both sides of the fixed furnace part on the inside of the (removable) furnace window. The two-part inner gas flow reaches the inside of the tube from the furnace windows and back out via the pipetter opening and the pipetter insert.

The inner gas flow has the task of removing all gases which occur in the graphite tube during the drying and pyrolysis step; also of preventing condensation effects of the analytes on the furnace windows and of influencing the residence time of the analyte atoms in the path of the beam. During atomization, the inner gas flow is generally interrupted in order to achieve the longest possible residence time for the atoms in the path of the beam of the graphite tube and to increase the sensitivity of the measurement.

Oxidizing or reducing gases (air or H_2) can be added to the inner gas flow if necessary. They have a positive effect on the pyrolysis step. When using air, temperatures $> 650^\circ C$ should be avoided since the graphite tube itself will then be attacked.

The outer gas flow flows through a channel in the fixed furnace part, the opening for the radiation sensor and the lower electrode into the furnace chamber. It sweeps the radiation sensor and the graphite tube and also reaches the outside through the pipetter insert. The outer gas flow is responsible for ensuring that the graphite tube is surrounded by inert gas, even when the inner gas flow has stopped, and thus provides protection against oxidation by atmospheric oxygen.

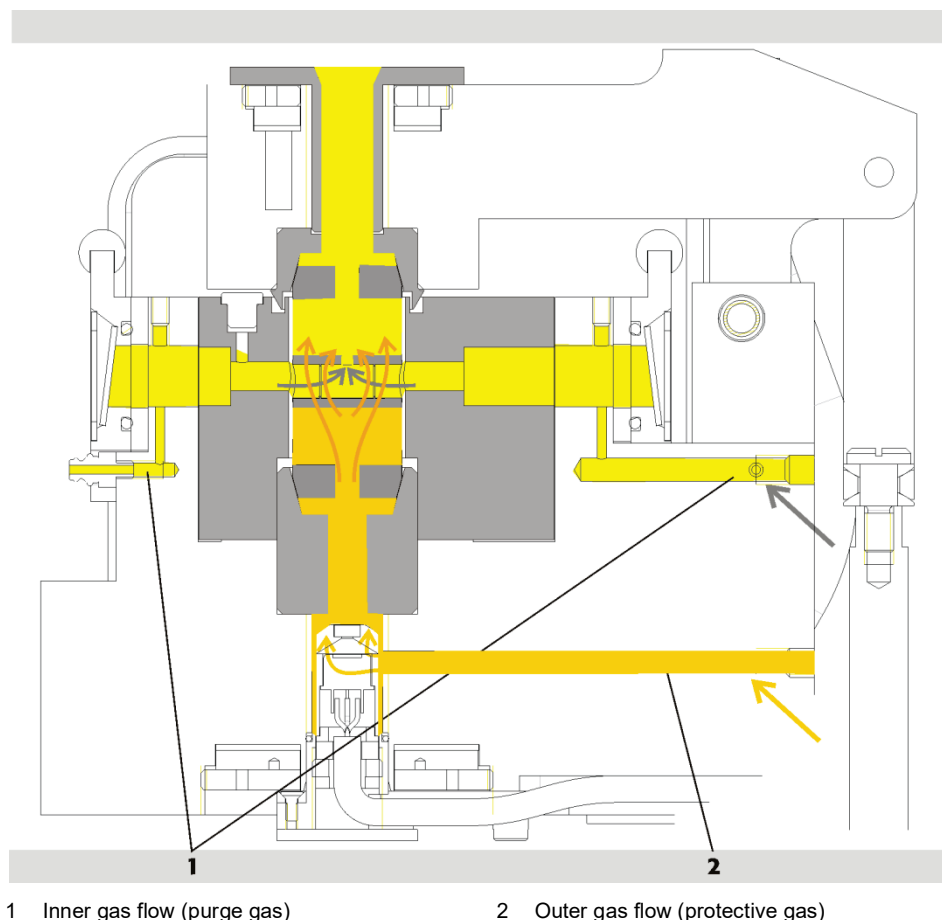

Fig. 10 Inner and outer gas flows in the graphite furnace

5.2.4 Graphite tube variations, furnace parts and inserts

Three graphite tube variations are available:

- Standard graphite tube
- Graphite tube for solid analysis
- Graphite tube with PIN platform

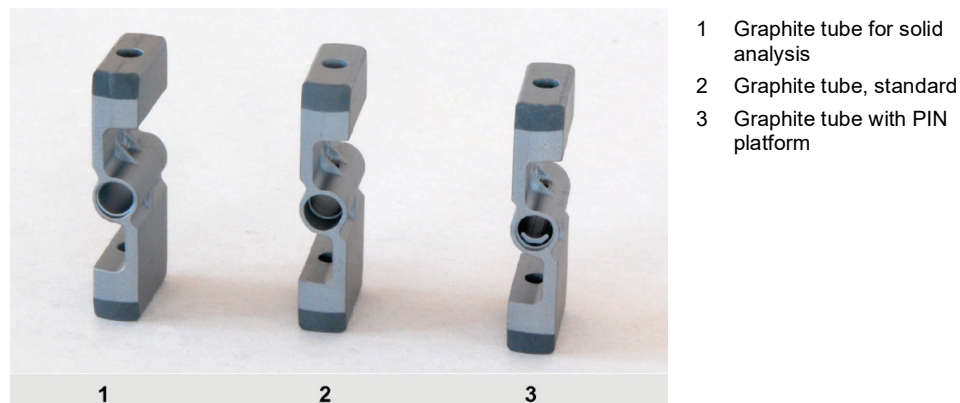

Fig. 11 Graphite tube variations

Graphite tube variation	Atomization	Sample volume / -quantity	Use
Standard graphite tube	Wall	Max. 50 μ L	Aqueous samples (samples not requiring complex analysis) Alternative for solid samples
Graphite tube with PIN platform	Platform	Max. 40 μ L	Aqueous samples
Standard graphite tube for solid analysis (without dosing opening)	Boat	Max. 3 mg	Solids (solid technology)

Table 4 Use and sample volume of different graphite tube variations

The wings of all tube types are drilled through. The hole in the lower wing serves as an observation channel for the radiation sensor. The hole in the upper wing lies in the extension of the pipetter opening as an access for pipetting in liquid samples.

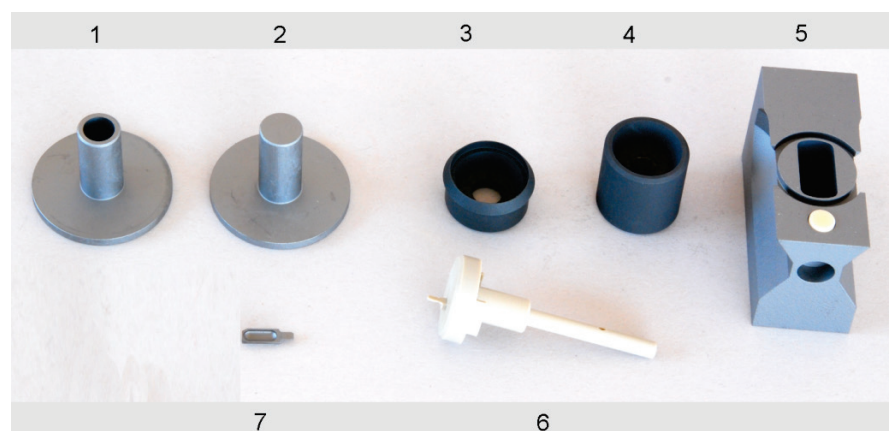

Fig. 12 Furnace shroud, adapters and inserts

No.	Furnace Part / Insert	Function
1	Pipetter insert (Z-insert)	Funnel opening to the pipetting channel. Protects exposed metal parts. Ensures contamination-free pipetting.
2	Solid adapter (Z sealing cup)	Seals the pipetter opening. Protects exposed metal parts.
3	Upper electrode	Contacts tube wing from above.
4	Lower electrode	Contacts tube wing from below.
5	Furnace shroud with horizontal hole going right through	Accommodates the graphite tube.
6	Adjusting aid	Adjusts the autosampler AS-GF and the solid autosampler SSA 600
7	Boat (sample carrier)	Accommodates solids samples.

Table 5 Furnace parts and inserts

5.2.5 Radiation sensor

The radiation sensor is used for recalibrating the tube temperature. It is fixed in the furnace holder and receives the radiation from the cylindrical part of the graphite tube through the drilled hole in the lower wing and through a concentric drilled hole in the lower electrode.

Using two wavelengths for detection, an independent quotient signal is derived for temperature measurement which is independent of the degree of radiation of the graphite tube. Recalibration takes place when formatting the graphite tube.

5.2.6 Furnace camera

As an option the ZEEnit 650 P can be fitted with a furnace camera. It monitors the process, beginning with the injection of the sample into the graphite tube through to completion of drying. The dipping of the dosing tube into the graphite tube, the dispensing of the sample and other components as well as the drying procedure can be controlled and corrected if necessary.

The camera looks into the graphite tube via a deflection mirror from the left. The interior of the graphite tube is illuminated by a LED from the right. The camera and the deflection mirror are mounted on a pneumatically actuated carriage and are moved into the path of the beam for observation. The illumination is rotated.

5.3 Accessories for the graphite tube technique

5.3.1 Autosampler AS-GF

The autosampler AS-GF is used in the EA mode for feeding the liquid samples and in the HydrEA technique for feeding the reaction gas into the graphite tube.



Note

Manual pipetting is not recommended because of the poor reproducibility rate.



Fig. 13 Autosampler AS-GF

The autosampler AS-GF accepts defined volumes of different solutions and places them into the graphite tube. It enables the

- Addition of up to five modifiers to the sample solution
- Transport of the sample solution to the thermal pretreatment in the tube
- Enrichment of samples
- Placement of components in the preheated tube
- Separate transport of components with intermediate washing
- Automatic preparation of standards by dilution or by different volumes
- Fixed, preselected or intelligent sample dilution
- Fully automatic multi-element mode (night mode possible)

The sample tray of the AS-GF has space for 100 sample cuts (with $V = 1.5 \text{ mL}$) and 8 central cups for diluent, special samples, standards, modifiers etc. (with $V = 5 \text{ mL}$).

The AS-GF is hung in the adapters provided in the sample chamber and electrical-ly connected to the ZEEnit 650 P. The device parameters of the AS-GF are set with the ASpect LS control software.

5.3.2 Mobile cooling unit KM 5

The graphite furnace of the ZEEnit 650 P is cooled by the mobile cooling unit KM 5 via a circulating cooling system. The working principle is an air-cooled heat exchanger with fan. The effective cooling power of the air-cooled mobile unit is therefore only available when the programmable set point is at least 7°C above room temperature. The maximum set point value is 50°C. The alarm value is always 15°C above the set point value. If cooling performance is no longer effective, a temperature alarm contact switches off the cooler and the spectrometer.

The KM 5 has to be filled with 5 L of softened water (not distilled water). The cooling water temperature can be set.

5.3.3 Solid autosamplers SSA 600 and SSA6

The solid autosamplers SSA 600 and SSA 6 are absolute preconditions for solids analysis in the graphite tube technique. These enable reproducible placement of the IC sample carrier mounted with the solid sample into the graphite tube.

The solid autosampler SSA 600 enables automatic transport of solid samples into the graphite furnace. Weighing is performed fully automatically with an integrated microbalance. The solid autosampler SSA 600 has 84 sample positions when using 2 sample plates.

The SSA 6 has been conceived for manual operation and requires an external balance. The sample mass must be transferred manually to the sample table.

A full description of the solid autosamplers can be found in the operating instructions "Solid autosampler SSA 600" or "Solid autosampler SSA 6".

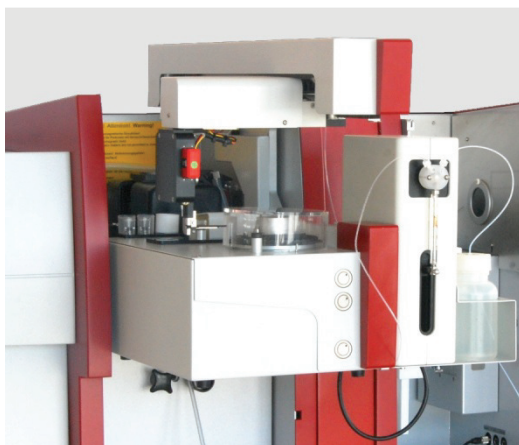

SSA 600 with liquid dispensing



SSA 6

Fig. 14 Solid autosamplers for ZEEnit

5.4 Mercury/hydride systems

The Hg/Hydride systems available range from simple batch systems for users with small samples through to fully automated continuous devices with flow injection.

HS 55 modular: Batch system with electrically heated cell unit with or without "Hg Plus" module for Hg detection. The reduction agent solution is metered by a 1-channel hose pump.

HS 60 modular: Hg/Hydride system for flow injection operation with electrically heated cell unit with or without "Hg plus" module for Hg detection.

More information on the Hg/Hydride systems can be found in the relevant accessory manuals.

5.5 The autosamplers AS-F and AS-FD as an accessory for the hydride and HydrEA technique

Manual or automatic sample supply may be employed in the flame technique and the mercury/hydride technique. Automatic operation and multi-element analysis are possible if an autosampler is used. The parameters are set and the function is controlled with the ZEEnit 650 P control software.

The ZEEnit 650 P P can be operated with the following autosamplers:

- The autosampler AS-F is an automatic autosampler.
- The autosampler AS-FD also has a dilution function.

The autosamplers use sample trays with the same diameter. The following sample tray types are available: :

139 positions	Sample tray with 129 sample positions for 15 mL Sarstedt cups on the outer track and 10 sample positions for 50 mL Sarstedt cups on the inner track
54 positions	Sample tray with 54 positions for 50 mL Sarstedt cups

The sample trays should be selected according to the requirements of the sample analysis:

- Available sample volume
- Type of signal evaluation

The software controlled autosampler arm reaches all the positions intended for sample-taking. The dipping depth into the sample and the special cups is preset, however, it can be adjusted via the control software.

The ZEEnit 650 P supplies the autosamplers with operational voltage. Tray and autosampler arm are driven by stepping motors. The tray is rotated. The autosampler arm is rotatable and can be lowered by 120 mm.

On the top of the autosampler AS-F there is a wash cup with overflow next to the sample tray. In the autosampler AS-FD the wash cup is located in a plastic block together with a mixing cup. A diaphragm pump delivers the washing liquid from the supply bottle into the wash cup – this action cleans the dipped canula by washing it

inside and out. Excess washing liquid flows through the overflow into the waste receptacle, which is under the table during the wash cycle.

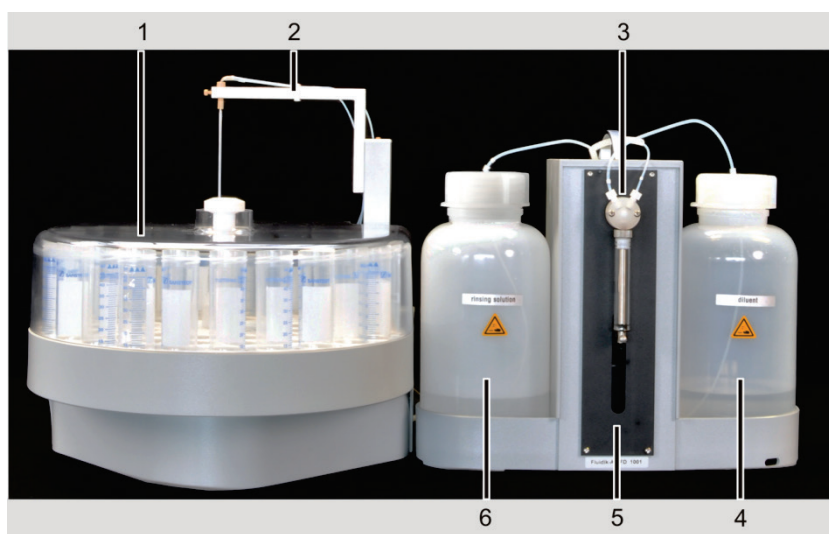

- | | | | |
|---|----------------------------|---|-----------------------------------|
| 1 | Sample tray with cover | 4 | Storage bottle for diluent |
| 2 | Autosampler arm | 5 | Fluidics module |
| 3 | dosing unit (5000 μ L) | 6 | Storage bottle for washing liquid |

Fig. 1 Autosampler AS-FD with separate Fluidics module

The autosampler AS-FD features an extra Fluidics module with a dosing unit (5000 μ L). The Fluidics module is electrically connected to the autosampler and is supplied with operating voltage via the ZEEnit 650 P. Standards or samples are diluted in the mixing cup by first placing the concentrate into the mixing cup. Then the diluent is added at a high dosing speed (max. volume: $V = 25$ mL). A fixed waiting time ensures complete mixing. A second diaphragm pump extracts the residual liquid that has not been taken up by the nebulizer.

The autosampler AS-FD with dilution function features the following advantages:

- Preparation of standards for the calibration by diluting one or several stock standards in the mixing cup
- Dilution of the sample if its concentration is too high, i.e., its element content is higher than 110 % of the calibration standard with the highest concentration
- Dilution of all samples at freely selectable dilution ratios up to a ratio of 1:500

5.6 Lamp turrets and lamps

The ZEEnit 650 P has a 8-lamp turret with a write/read unit (RFID) for coded lamps at the active position. The coded lamps are fitted with transponders. The following is saved: lamp type, element(s), serial number, maximum recommended lamp current and boost current and operating hours. The use of uncoded lamps is possible. The lamp turret is designed for hollow cathode lamps with a standard bulb diameter of 37.1 mm. The individual lamps are rotated (PC-controlled) into the beam path, switched on and adjusted relative to the pitch circle in steps of 0.1 mm-

A second heat circuit ensures that a second HCL can be preheated at the same time.

Positions 5 to 8 can also be mounted with super- hollow cathode lamps. The required supply for boost current and heating is integrated and can be switched for either one of the positions 5 to 8. If a super- HCL is used as an active lamp, a second super- HCL cannot be preheated as such, only as a HCL. Therefore, for the multi-element routine it is recommended to have an element method with a super HCL followed by a method with a normal HCL.

Using a super hollow cathode lamp is advantageous for some elements such as As, Se, Te, P, Zn due to the higher intensity of radiation, which enables the signal to noise ratio and the detection limit to be improved.

For mounting the 8-lamp turret, the following combinations can be used:

- 8 coded hollow cathode lamps or multi-element- hollow cathode lamps
- 1 to 4 coded super- hollow cathode lamps at positions 5 to 8 and the remaining positions with coded hollow cathode lamps or multi-element- hollow cathode lamps.

The continuum emitter, a deuterium hollow cathode lamp (D2HCL), is installed in a separate holder.

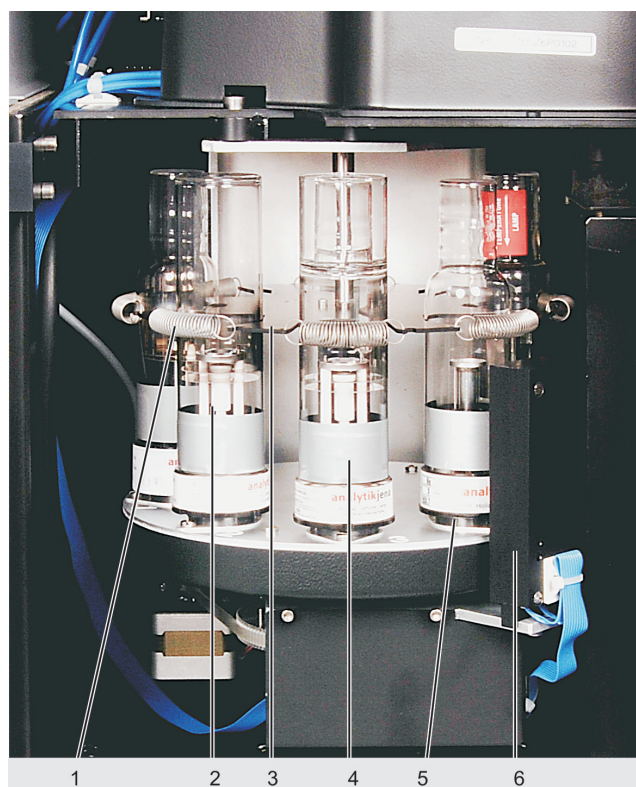

- 1 Spring
- 2 Lamp
- 3 Disk with prism holders for lamps
- 4 Transponder
- 5 Lamp holder, floating
- 6 Antenna

Fig. 15 Setup of the lamp turret

6 Installation and start-up



Prevent any unauthorized interference!

The device may only be assembled, installed and repaired by service engineers from Analytik Jena or by technical personnel authorized by Analytik Jena.

Any unauthorized interference limits warranty entitlements. When installing and starting up your machine, please observe the safety instructions in Section "Safety instructions" S. 9. Compliance with these safety instructions is a requirement for error free installation and the proper functioning of your AAS measuring environment. Always observe all warnings and attention messages which are displayed on the device itself or which are displayed by the control program of the ZEEnit 650 P.

For error-free operation of the ZEEnit 650 P, please ensure that the user instructions described in Chapter "

Installation conditions" S. 25 are always complied with. If the ZEEnit 650 P has to be moved, please follow the instructions in Chapter "

Transporting the ZEEnit 650 P" S. 94.

6.1 Supply and control connections

The supply lines are connected during the assembly of the ZEEnit 650 P by service engineers from Analytik Jena.

The mains switch is located on the right side of the ZEEnit 650 P. The right side also has easily accessible connections for PC and accessories. The media connections for gas, water and electricity as well as the fuses are located at the rear.

A pair of carrying rods are fastened to the left and right for transport and assembly. After assembly the bars are unscrewed and the openings sealed with the stoppers supplied.



- | | | | |
|------|------------------------------|---|---|
| 1 | Mains switch | 6 | Connections for PC and accessories |
| 2; 5 | Opening for carrying bars | 7 | Media connections on the rear of the device |
| 3; 4 | Clamp for fastening the hood | | |

Fig. 16 Mains switch and bar for supply and control connections on the right side of the ZEEnit 650 P

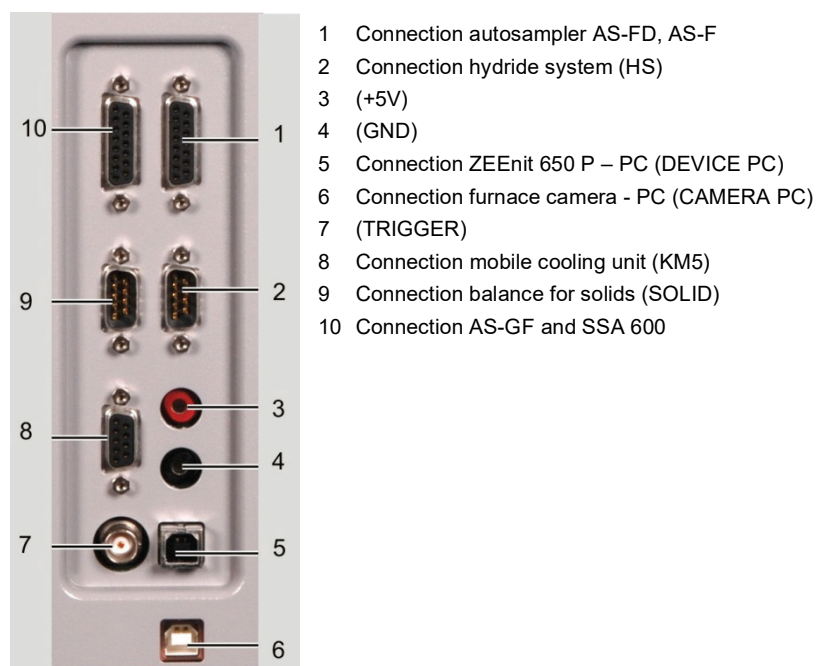

Fig. 17 Bar for supply and control connections



- | | |
|--|--|
| 1 Connection inert gas | 6 Mains connection line for ZEEnit 650 P |
| 2 Connection auxiliary gas | 7 Fuses F9 – F14 |
| 3 Fuses F3 – F8 | 8 Cooling water inlet "Water in" |
| 4 Mains connection for accessories
(5-way multiple adapter) | 9 Cooling water outlet "Water out" |
| 5 Fuses F1, F2 | |

Fig. 18 Rear view of the ZEEnit 650 P with connections for the supply of gas, electricity and water, as well as the fuse holders

6.2 Removing the transport lock



Remove the transport lock!

The transport lock must be removed by service engineers from Analytik Jena or technical personnel authorized by Analytik Jena.

1. Unscrew and remove the clamps for the device cover on the left and right side walls (3 and 4 in Fig. 16).
2. Remove the device cover.
3. Unscrew the red-marked transport lock from the grid lever.
4. Fit on the cover of the device and fasten the clamps on the left and right side walls.

6.3 Installing the ZEEnit 650 P



Caution! Only service engineers are allowed to install the device!

The device may only be installed by service engineers from Analytik Jena or by technical personnel authorized by Analytik Jena.



Ensure that installation conditions are guaranteed in the new installation area!

See Chapter "

Installation conditions" S. 25.

Pay attention to the safety instructions in Chapter "Safety instructions" S.9. Observe work protection regulations. Warnings regarding potential dangers do not replace valid work protection regulations!

Auxiliary materials

- 4 stoppers, plastic
 - 19 mm open-end wrench (included in scope of supply)
1. Unscrew and remove the four handles and keep in a safe place.
 2. Seal the openings with stoppers.
 3. Install the gas supply:
 - Fix the argon tube to the screwed tube connection.
 4. Check the gas connections for leaks (→ Section "Supply and control connections" S.48).
 5. Install the mobile cooling unit KM5 (→ Section "Installing the mobile cooling unit KM 5" S. 51).
 6. Establish the electrical connection of the ZEEnit 650 P (→ Section "Energy supply" S. 27).
 7. Connect the PC and the ZEEnit 650 P with USB cable (5 in Fig. 17).
 8. Further work steps:
 - Install the ASpect LS software
 - Complete the ZEEnit 650 P according to the desired atomization technique

6.4 Installing the mobile cooling unit KM 5

For all information on installation, operation and maintenance, consult the supplied instruction manual "Mobile Cooling Unit KM5".

1. Fill the mobile cooling unit KM 5 (see Section "Mobile cooling unit KM 5" S. 93).
2. Set up the cooling circuit: Push the tube connector onto the ZEEnit 650 P and KM 5.

At the KM5 (below): "Water inlet" → On the ZEEnit 650 P: "IN"

At the KM5 (above): "Water return flow" → On the ZEEnit 650 P: "OUT"

3. Connect the control cable of the KM 5 to the appropriately marked connector on the right wall of the ZEEnit 650 P (see Fig. 18).
Note: The service button of the KM 5 remains at "OFF", i.e., the green operating light does not light up. This is the only way of ensuring that the mobile cooling unit can be controlled by the ZEEnit 650 P control software.
4. Bleed the cooling circuit (→ Section "Mobile cooling unit KM 5" S.93).

6.5 Installation and start of the ASpect LS program

For the installation and start of the ASpect LS program, which is required for controlling the spectrometer, refer to the Manual "ASpect LS."

6.6 Mounting the 8-lamp turret and lamp adjustment

A 8-lamp turret can be mounted as follows:

- The 8-lamp turret should preferably be mounted with coded hollow cathode lamps.
- The use of uncoded lamps is also possible.
- The positions 5 to 8 can also be mounted with super hollow cathode lamps.

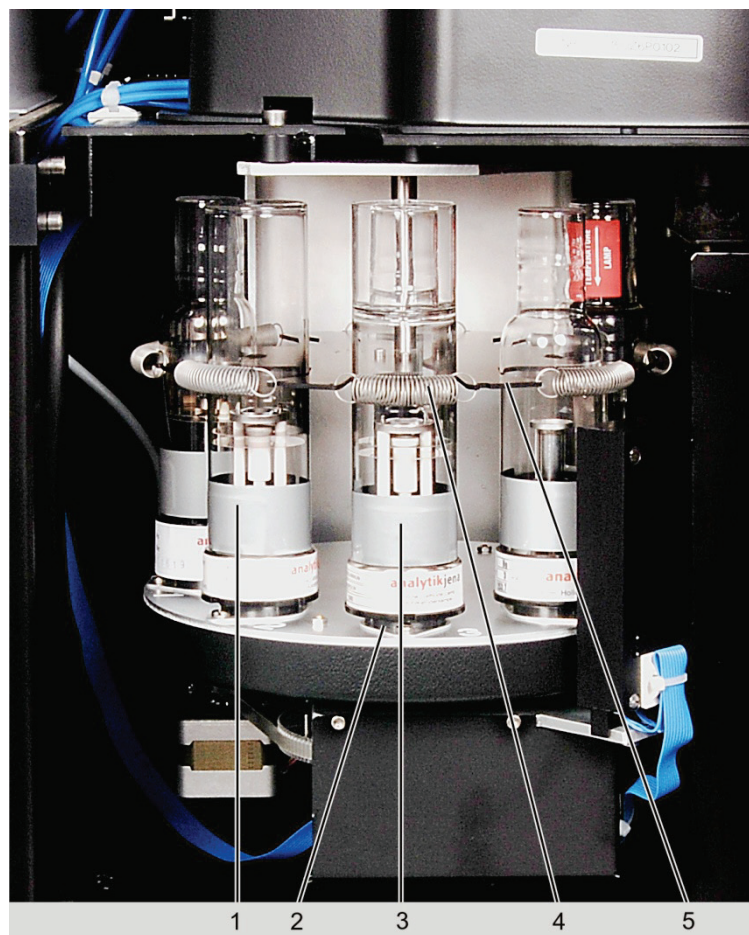

- 1 Hollow cathode lamp
- 2 Lamp socket
- 3 Position of the lamp turret for removal and installation of the HCLs
- 4 Tension spring
- 5 Disk with prism holders for HCL

Fig. 19 Setup of the lamp turret

6.6.1 Removing and installing the hollow cathode lamp



Warning! Risk of burning!

Before changing the lamp, switch off the lamp current and allow the lamps to cool down.



Caution! Risk of damage to lamp!

Do not touch the lamp window.

Remove and install lamps only when no current is flowing.

Only use your hand when opening and closing the door to the lamp turret chamber.

1. Open the door to the lamp chamber.
2. Unhook the tension spring.
3. Remove the lamp from the lamp socket.
Note: Do not touch the lamp window!
4. Plug the new lamp into the lamp socket, hook the tension spring in again.

6.6.2 Removing and installing the deuterium hollow cathode lamp



Warning! Risk of burning!

Before changing the lamp, switch off the lamp current and allow the lamps to cool down.



Caution! Risk of damage to lamp!

Do not touch the lamp window.
Remove and install the lamp only when no current is flowing.

1. Remove the cover plate of the D2HCL holder from the device cover.
2. Unscrew the three fixing nuts (arrow in Fig. 20) and remove the lamp holder.
3. Unscrew the retaining screw (6 in Fig. 21). Pull the lamp socket from the lamp.
4. Carefully pull out the lamp under the tension spring (1 in Fig. 21).
5. Place the new lamp carefully under the tension spring and push it to the stop (2 in Fig. 21).
Note: Do not touch the lamp window!
6. Put the socket on the lamp. Screw in the retaining screw.
7. Adjust the lamp axis parallel to the mount of the holder (by eye): Change the position of the lamp (4 and 5 in Fig. 21) with the long fine adjusting screws.
8. Fit on the holder and screw on the fixing nuts loosely. They are tightened by hand only after the adjustment.

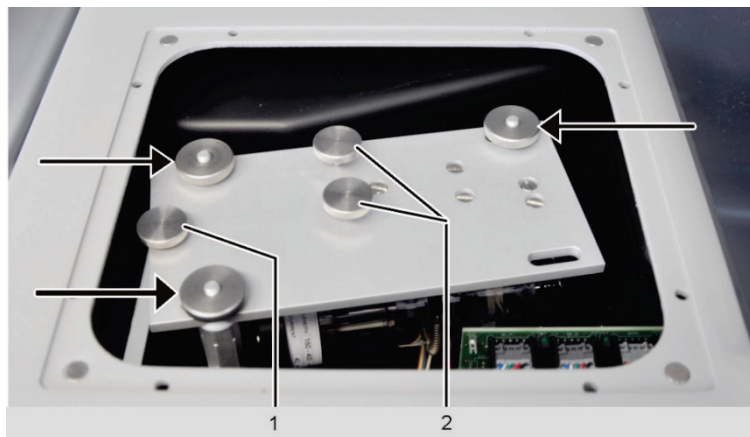

- Arrow
- Fixing nuts of the lamp holder
 - 1 Retaining screw for the lamp socket
 - 2 Adjusting screws

Fig. 20 D2HCL holder installed in the lamp chamber

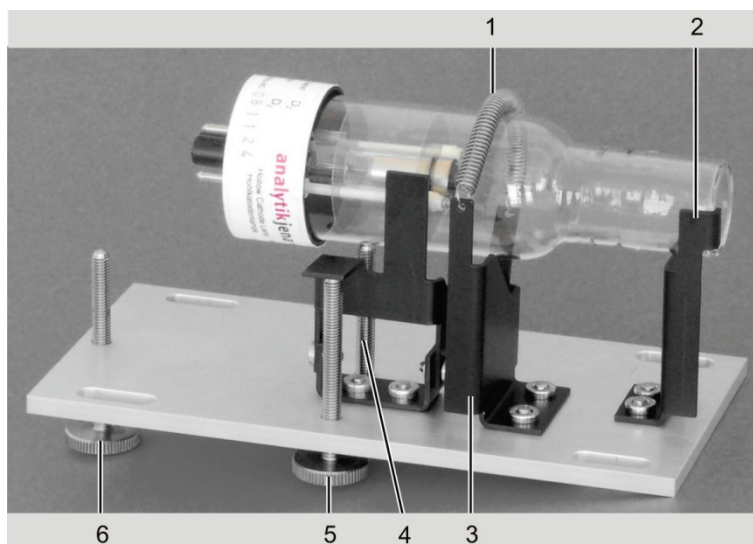

- | | |
|------------------|---------------------------------------|
| 1 Tension spring | 4; 5 Fine adjusting screws |
| 2 Stop | 6 Retaining screw for the lamp socket |
| 3 Support | |

Fig. 21 D2HCL with the holder removed from the lamp chamber and positioned for lamp change

6.6.3 Setting up the lamp turret in ASpect LS

Coded lamps

If coded lamps are available, the data which is important for the method of analysis and which is saved on the transponder, such as the lamp type, elements, maximum and recommended lamp current as well as maximum and recommended boost current, is read out in the active position during initialization and entered in the table with the assignment to the lamp turret position.

Uncoded lamps



Caution! Observe the lamp position!

If the hollow cathode lamps are not coded, the lamps must only be mounted according to their entered positions in the turret.

1. Click the  icon to call up the Spectrometer window and then go to the Control tab.
2. Use the **[Lamp turret]** button to open the corresponding window.
3. In the table, highlight the lamp turret position that is to be mounted with a lamp or which is to be changed.
4. Use **[Change]** to open the **Select lamp/element** window.

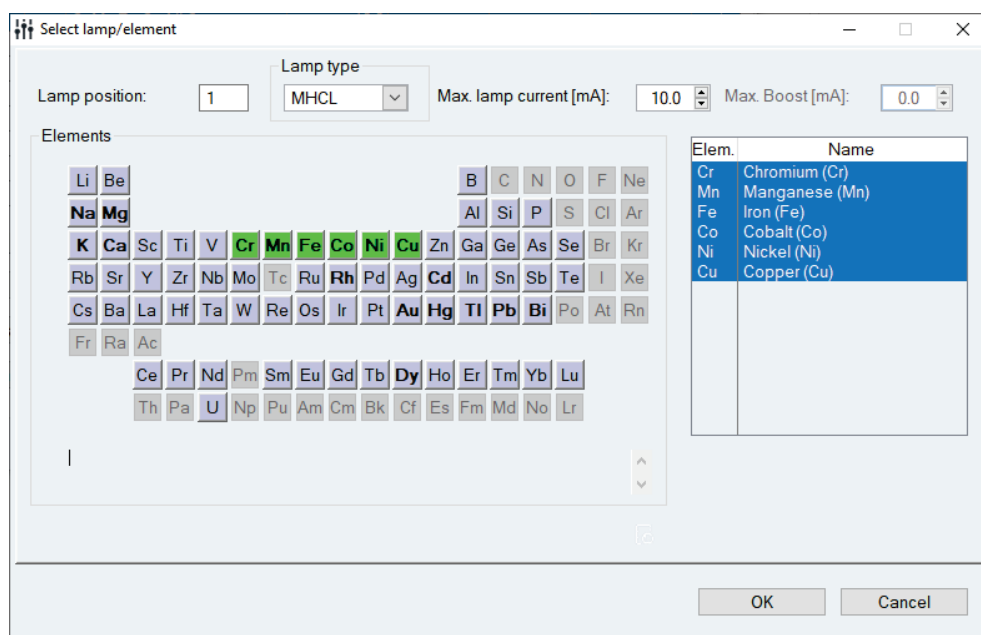

Fig. 22 Select lamp/element window

5. Enter the following values:

Lamp position Shows the position in the lamp turret.
Cannot be edited in this window.

Lamp type For selecting the lamp type. The selection is based on the lamp position and the lamp types available at the position. S-HCL and S-MHCL are only available at the positions 5 to 8.

none The position does not contain a lamp.

HCL Single-element hollow cathode lamp

M-HCL Multi-element hollow cathode lamp

S-HCL Single-element super hollow cathode lamp

S-MHCL Multi-element super hollow cathode lamp

Current For setting the maximum lamp current.

Boost *Only for S-HCL and S-MHCL*

For setting the maximum boost current.

Periodic table Click with the cursor on the element symbol in the periodic table to select the lamp element:
Blue buttons indicate selectable elements. Gray (inactive) buttons indicate elements that cannot be analyzed with the AAS technique. Green buttons indicate selected elements. For M-HCL and S-MHCL several elements can be selected. Click on the element symbol again to cancel the selection. Selected elements are displayed in the table on the right.

6. Click **[OK]** to exit the **Select lamp/element** window and return to the **Lamp turret** window.

The lamp specification is entered into the table of the **Lamp turret** window.

6.6.4 Adjusting the lamps

Fine adjusting the lamps is generally done only once. The energy display is switched on for this and the lamps are optimally aligned in the optical path of the beam.

Maximizing the lifetime of the lamp

The lifetime of the lamp is strongly dependent on the current setting for the lamp. The recommended operating current varies from lamp type to lamp type. In the following adjustment, observe the instructions in the cookbook of the ASpect LS software, the Analytik Jena operating instructions for the various lamps and the information supplied with the lamp.

Work steps: Line radiator

1. Click the  icon to call up the Spectrometer window and then go to the Control tab.
2. Use the **[Lamp turret]** button to open the corresponding window.

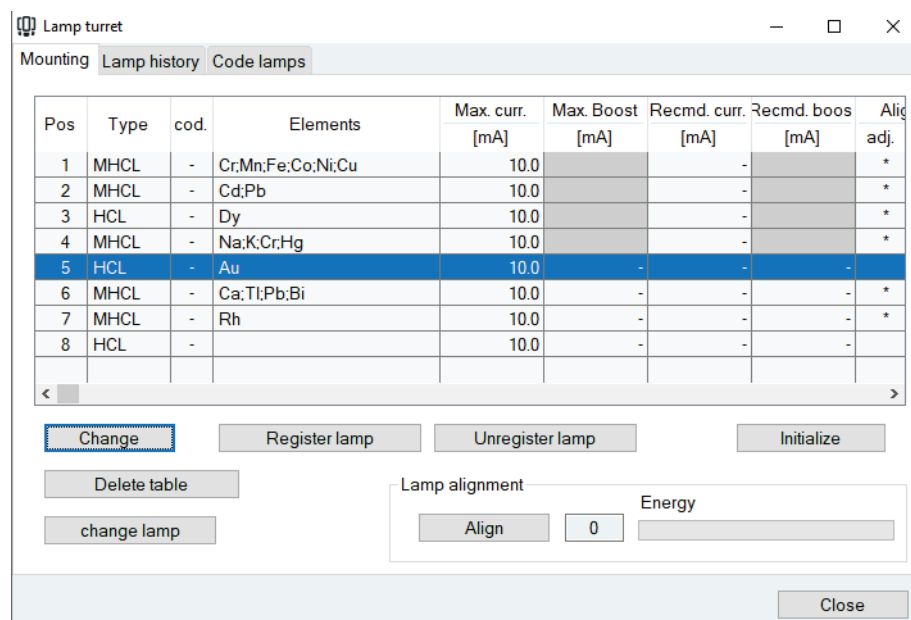



Fig. 23 Lamp turret window

3. Highlight the lamp to be adjusted in the table.
4. Click the **[Align]** button.

The lamp is then automatically adjusted relative to a pitch circle. In the Lamp alignment area, the energy is displayed as a **blue** bar during the adjustment.

Work steps: Deuterium hollow cathode lamp

1. Click on the  icon to call up the **Spectrometer** window and then go to the **Control** tab.
2. In the **Background correction** list, select the **D2 background only** option.
3. Approach the spectrometer parameters using **[Set]**.
4. Go to the **Energy** tab.

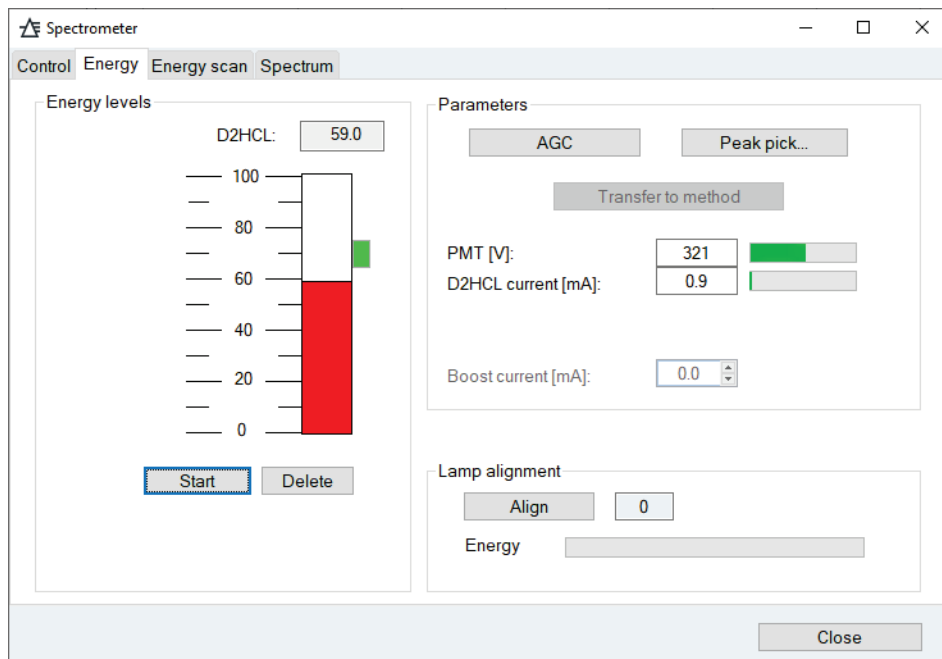

Fig. 24 Spectrometer window - Energy

5. With the **[AGC]** button, equalize the voltage for the photomultiplier PMT and the D2HCL current with the aim of setting the energy level to 65 to 75%.
6. With the **[Start]** button, begin the energy measurement.
7. Set the energy level (red bar) to a maximum value:
Note: The gray highlighted bars indicate the last maximum to have been reached and can be deleted with the **[Delete]** button.
 - With focus adjusting: Move the lamp holder slightly by hand in the axial direction, then tighten the locking screws.
 - With axis adjusting: Adjust the fine adjusting screws (2 in Fig. 20 p. 54).

Proceed, depending on possible error messages or the D2 current:

- If an error message indicates too little energy for the D₂-HCL, first check the D2 current. If it is not at 35 mA after the control, enter the value 35 mA and repeat the control using the **[AGC]** button.
- If the D2 current is already at 35 mA, increase the BC amplification by one step (steps from 0 to 4) and repeat the control using the **[AGC]** button.
- If an error message indicates too much energy for the D₂-HCL (too little energy for the HCL), increase the HC amplification by one step (steps from 0 to 4) and repeat the control using the **[AGC]** button.

6.7 Graphite tube technique

6.7.1 Connections in the sample chamber for the graphite tube technique

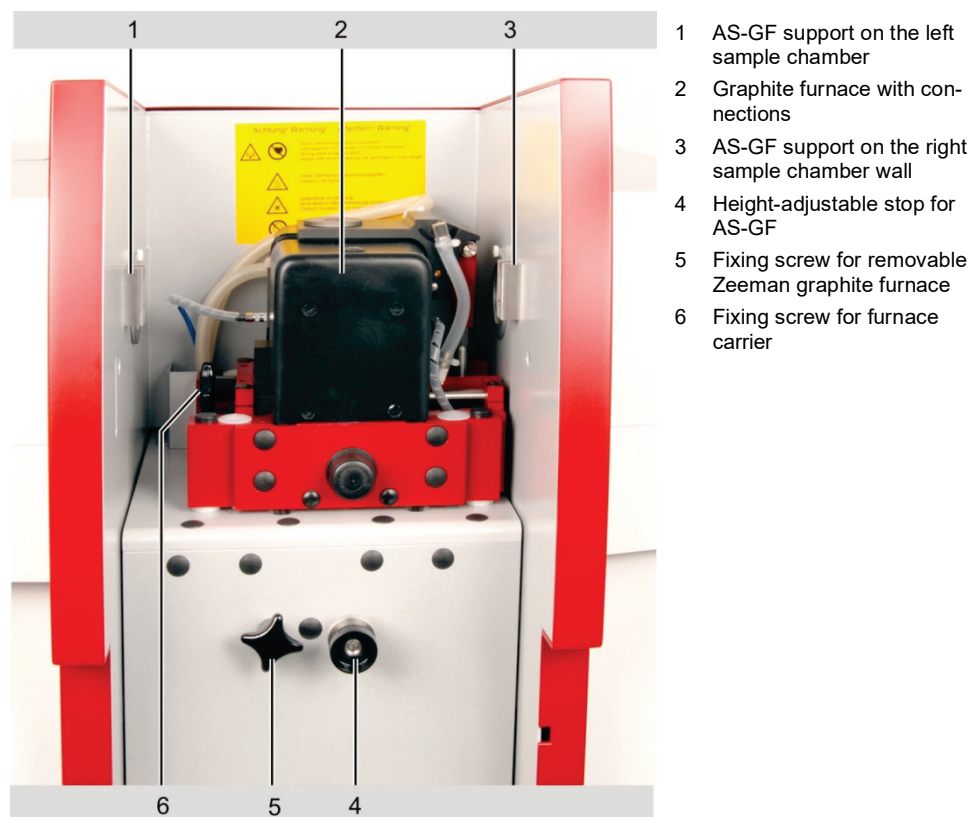

Fig. 25 Elements in the sample chamber for the graphite tube technique

The graphite furnace is adjusted by the manufacturer. The connections for gas and cooling water are fixed installed on the graphite furnace.

The ventilator for the high-current transformer is located under the furnace behind the cover.

6.7.2 Software presettings for the graphite tube technique

The options for the graphite furnace technology are set in the start menu of the ASpect LS software. The software interface with the method and device parameters is adjusted accordingly.

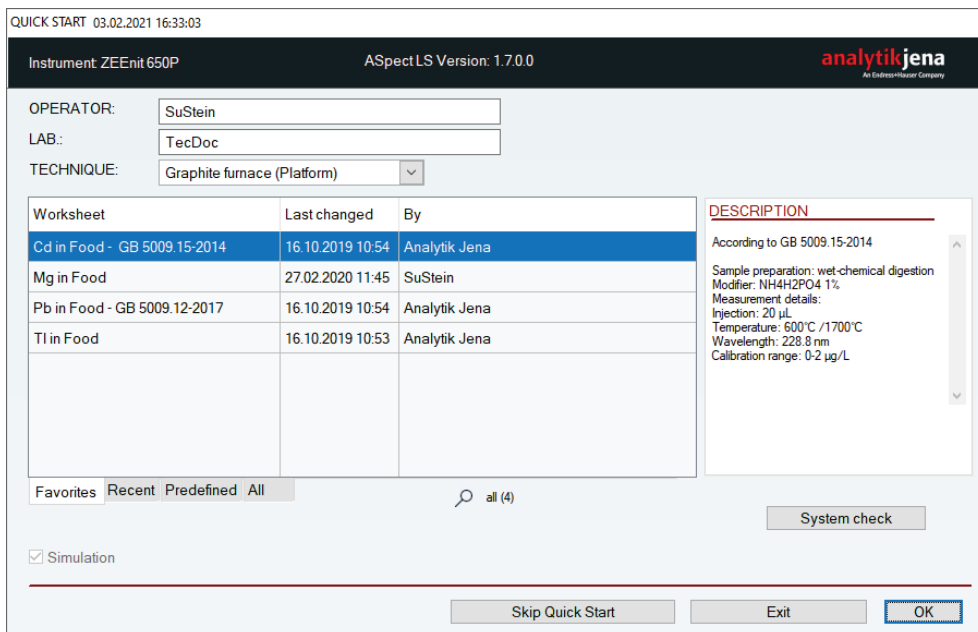

Fig. 26 Start menu of ASpect LS with settings for the graphite tube

6.7.3 Inserting the graphite tube into the graphite furnace

Removing and installing a graphite tube is necessary after the atomization method has been changed and after a certain number of atomizations has been carried out with the same graphite tube.



Caution!

Never touch the graphite tube with your bare fingers! Fingerprints burn into the surface, and this causes premature damage to the pyrolysis coating of the tube.

Inserting the graphite tube into the graphite furnace

1. Open the graphite tube furnace:
 - Use the  button to open the **Furnace – Control** window.
 - Click the **[Open furnace]** button.

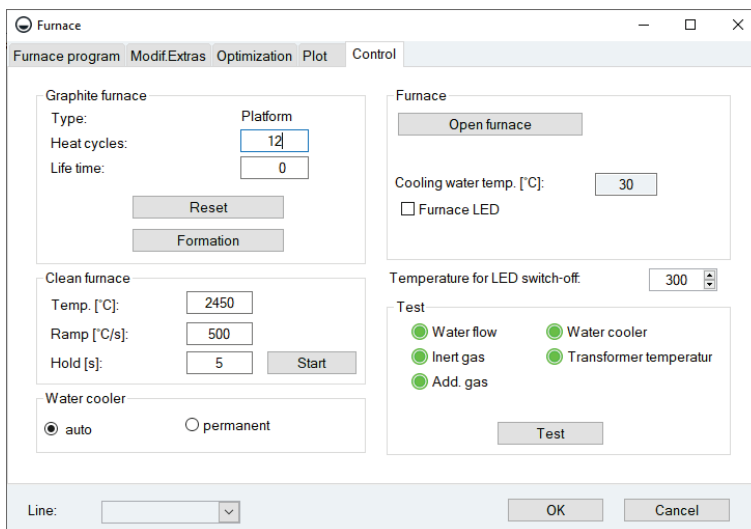

Fig. 27 Furnace - Control window

2. Clean the furnace shroud and electrodes if necessary (→ Section "Maintaining the graphite furnace" S. 75).
3. Insert the graphite tube (using tweezers or by hand, protected with cellulose wadding) into the graphite furnace so that the pipetter opening points upwards. There is no preferred direction for the graphite tube for solid analysis without a pipetter opening.
4. Close the graphite furnace with the **[Close furnace]** button.
5. In the **Graphite furnace area** enter the **Heat cycles** and **Life time** parameters of the inserted graphite tube.
6. Format the graphite tube: In the **Graphite furnace area** click the **[Formation]** button (→ Section "Formatting the graphite tube" p. 62).

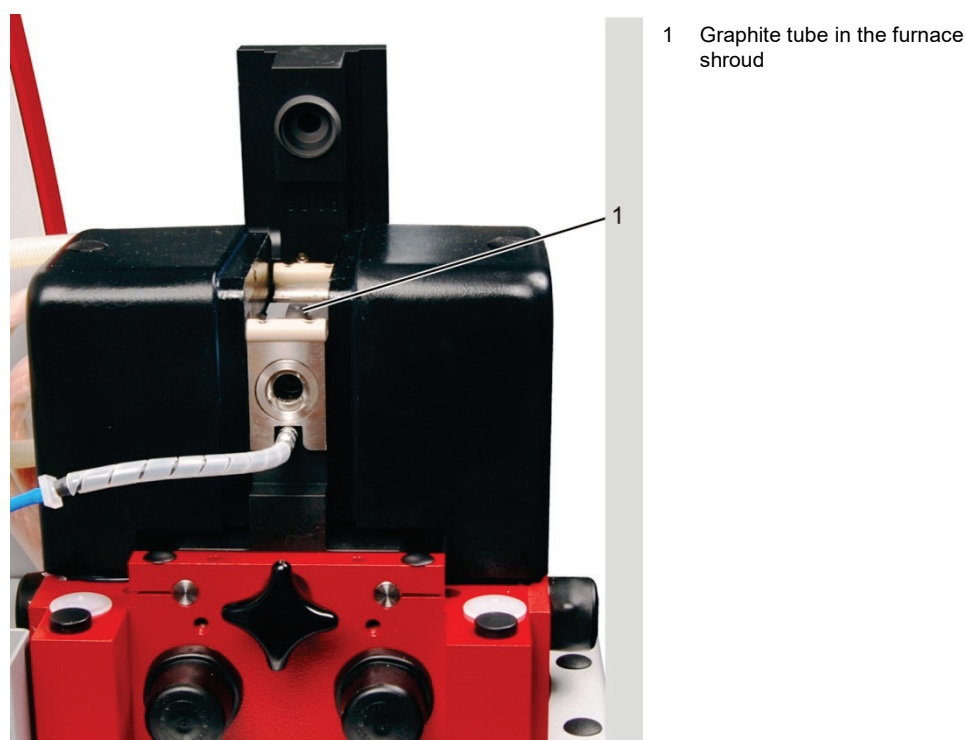

Fig. 28 Graphite furnace opened with inserted graphite tube

Removing the graphite tube from the graphite furnace



Warning! Risk of burning!

Allow the graphite furnace to cool down before removing the graphite tube.



Caution! Never touch the graphite tube with your bare fingers!

Fingerprints burn into the surface, and this causes premature damage to the pyrolysis coating of the tube.

1. Open the graphite furnace with the **[Open furnace]** button.
2. Remove the graphite tube with titan tweezers, or with by hand protected with cellulose wadding.
3. Insert the new graphite tube (see above) and/or close the graphite furnace.

6.7.4 Formatting the graphite tube

When the graphite tube is formatted the following takes place

- Atmospheric oxygen is expelled from the furnace and the force on the movable furnace part is adjusted
- The tube temperature is recalibrated
- The pyro coating is conditioned in the newly inserted graphite tube
- The furnace is cleaned after pausing

The furnace must be formatted after the following:

- Switching on the spectrometer
- After closing the previously opened furnace

The complete formatting program contains nine pre-programmed temperature stages.

Formatting is started in the **Furnace / Control** window. During formatting, the current temperature stage, time and ramp are displayed in the **Format tube** window. In the first five stages, the furnace and the graphite tube are cleaned and conditioned (contacts between the graphite tube and the electrodes are aligned). By means of a special sensor technique, the tube temperature in the remaining four stages is measured. After the last temperature stage, the formatting factor for the correction of the tube temperature is displayed. The corrected furnace temperature ensures correct measurement results.

At a formatting factor of > +10 % an automatic temperature correction no longer takes place, but the current temperature-time program (TTP) can still be started after confirming the corresponding screen message. The temperature may possibly have to be manually adjusted in the furnace program.

1. Use the  button to open the **Furnace – Control** window (→ Fig. 27 p. 60).
2. In the **Furnace – Control** window enter data specific to the current graphite tube:

New graphite tube	Heat cycles	0
	Life time	0
Used graphite tube	Heat cycles	Current value of the graphite tube
	Life time	Current value of the graphite tube

3. In the **Graphit furnace** area click the **[Formation]** button.

6.7.5 Cleaning the graphite tube / (clean out)

1. Use the  button to open the **Furnace – Control** window (→ Fig. 27 p. 60).
2. In the **Clean furnace** area set the following parameters:

Temp.[°C]	End temperature to be reached during clean out. The final temperature should be approx. 50 °C higher than the previous atomization temperature.
Ramp [°C/s]	Ramp
Hold [s]	Set the hold time
3. Start the clean out with the **[Start]** button in the **Clean furnace** area. Cleaning may be repeated several times, if required at a higher temperature.

Clean out/evaporation of iridium-coated graphite tube (HydrEA technique)

The following temperature program must be used for the iridium-coated graphite tube (see also operating instructions for the accessories):

	Clean out	Evaporation
Temp. [°C]	2200°C	2600°C or more
Ramp [°C/s]	500°C/s	500°C/s
Hold [s]	10 s	10 s
		Do not select a higher hold time, otherwise this may exceed the load limit of the furnace.

Clean out or evaporation can be repeated several times.

6.8 Autosampler AS-GF

6.8.1 Completing and installing the autosampler



Caution! Switch off the ZEE nit 650 P before installing or uninstalling the AS-GF!

The connection or disconnection of electrical plug-in contacts can cause a short circuit, which destroys the device.



Note

Choose a safe location for the completion of the AS-GF. The device can tilt easily.

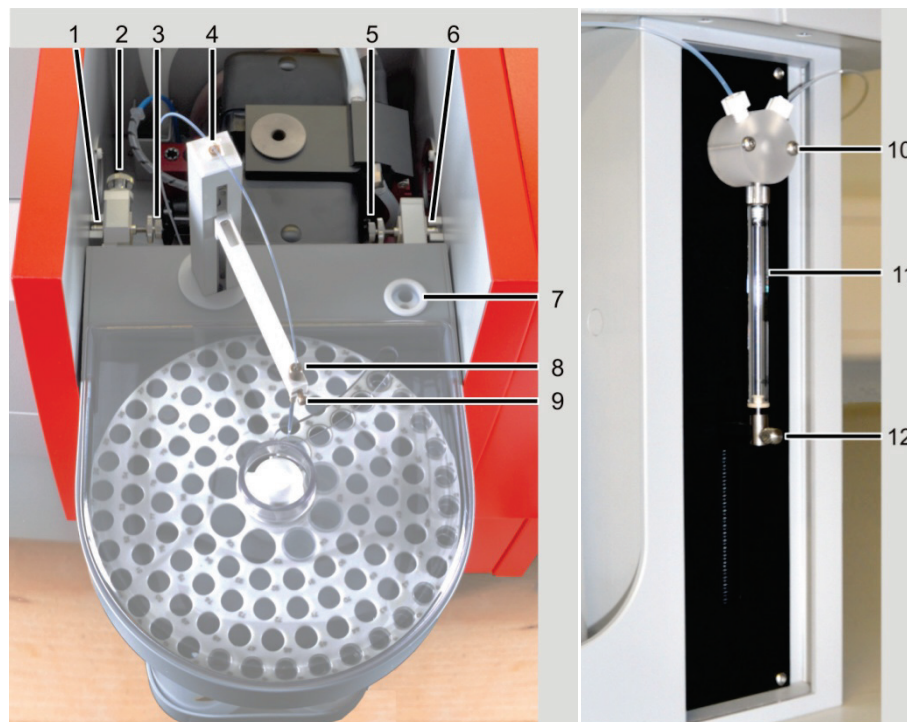

- | | | | |
|---|--------------------------------------|----|----------------------------|
| 1 | Left support in the sample chamber | 7 | Wash cup |
| 2 | Adjusting screw 1 (for Y coordinate) | 8 | Tube guide with clamp nut |
| 3 | Adjusting screw 2 (for X coordinate) | 9 | Lock screw |
| 4 | Tube holder | 10 | T valve of the dosing unit |
| 5 | Adjusting screw 3 (for X coordinate) | 11 | Dosing syringe |
| 6 | Right support in the sample chamber | 12 | Lock screw for piston rod |

Fig. 29 Installing the AS-GF

1. Install the tube guide (8 in Fig. 29) to the autosampler arm of the AS-GF and attach using the lock screw.
2. Screw the dosing tube into the right opening of the T valve (10 in Fig. 29) on the dosing unit. Feed the dosing tube through the tube holder on the back of the autosampler and on the autosampler arm. Insert the dosing tube into the tube guide (8 in Fig. 29) until the tube end protrudes approx. 8 mm from the tube guide at the bottom; attach the tube using a clamp nut.
3. Plug the control cable into the socket at the back of the AS-GF and lock it in place.
4. Hang the AS-GF on the supports in the sample chamber (1 and 7 in Fig. 25 p. 59). Using a spirit level, check whether the autosampler is suspended horizontally; if necessary, align the autosampler using the depth-adjustable stop in the sample chamber (4 in Fig. 25 p. 59).
5. If necessary, align the AS-GF with the furnace (coarse adjustment): manually rotate the autosampler arm over the dosing opening in the graphite tube. If the dosing tube does not align with the opening, the suspension of the autosampler must be moved forward or back. To this end unhook the autosampler from the sample chamber. Move the left and right suspension mounts with the aid of adjusting screw 1 and the set screw (2 and 4 in Fig. 30). Hook the autosampler back in.

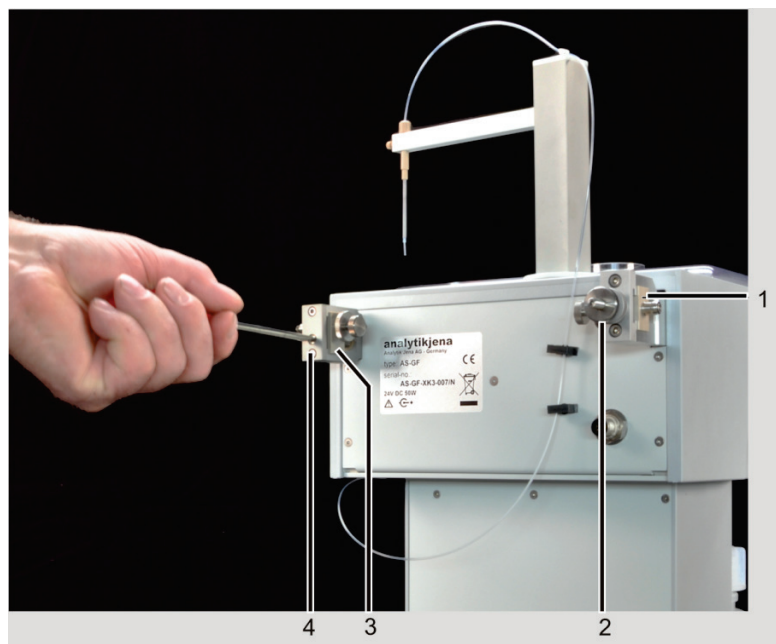

- | | |
|-------------------------------------|--------------------------------------|
| 1 Slider with left suspension mount | 3 Slider with right suspension mount |
| 2 Adjusting screw 1 | 4 Adjusting screw |

Fig. 30 Aligning the AS-GF with the furnace using the set screw and adjusting screw

6. Plug the control cable into the socket on the connection strip of the AAS device on the right side (10 Fig. 17 p. 49).
7. Place and fix the sample tray on the axis of the AS-GF.
8. Place the sample cover until it sits in the guide rail.
9. Switch on the computer and the ZEE nit 650 P, wait for the initialization steps to complete, start the ASpect LS software.
10. If necessary, fit the dosing syringe to the dosing unit (→ Section "Replacing the dosing device" p. 89).
11. Perform a fine adjustment of the autosampler (→ Section "Adjusting the AS-GF" p.66).

Preparing the autosampler for the HydrEA technique

Prior to installing the HydrEA technique the graphite tube must be coated with iridium or gold (see hydride system manual). Use the dosing tube used during graphite operation for this purpose.

1. Switch off the AAS device and install the hydride system (e.g. HS 60 modular).
2. For the HydrEA technique remove the tube guide and dosing tube from the autosampler arm of the AS-GF. Install the titan canula to the autosampler arm and attach it using the lock screw.
3. Attach the reaction gas tube to the titan canula.

6.8.2 Adjusting the AS-GF

The AS-GF has already been installed according to Section "Completing and installing the autosampler" S.63 in the graphite furnace sample chamber. The fine alignment of the AS-GF to the furnace is supported by software. The autosampler is aligned such that samples can be optimally deposited in the graphite tube.

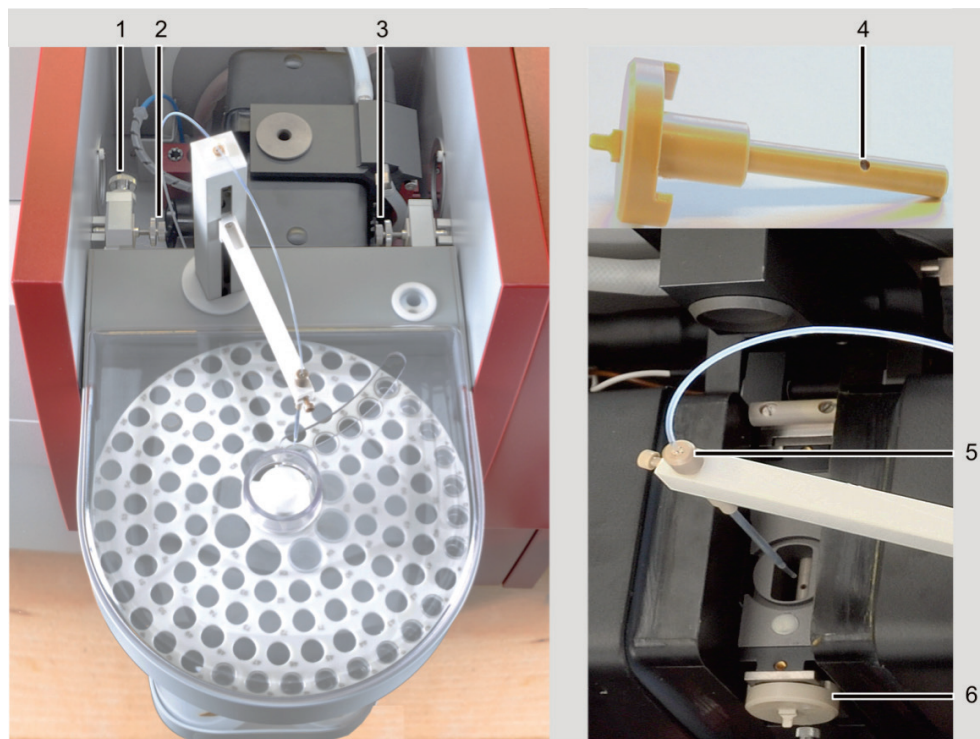

- 1 Adjusting screw 1 with lock nut
- 2 Adjusting screw 2 with lock nut
- 3 Adjusting screw 3 with lock nut

- 4 Adjusting aid
- 5 Tube guide with clamp nut
- 6 Adjusting aid in the open ZEEman furnace

Fig. 31 AS-GF adjustment

1. Start the ASpect LS software and open the **Autosampler** window with the symbol , change to the tab **Techn. Parameters**.
2. Start the adjustment using the **[Align MPE to furnace]** button.
3. Follow the prompts in the dialog fields of the software.

In the running program the following takes place:

- Alignment of the AS-GF with the furnace
- Adjustment of the dipping depth

Carry out the following work steps successively:

- Withdraw the dosing tube approx. 8 mm from the canula of the autosampler and fix it with a clamp nut.
- Open the ZEEman furnace and insert the adjusting aid into the furnace.
- Lower the autosampler via the software to the adjusting aid.
- Align the X direction with the buttons **[left]/[right]** to the crosshair.
- Adjust the Y direction using the adjusting screw 1.
- If required, readjust the X direction using the adjusting screws 2 and 3.
- Adjust the Z direction software-controlled:
Lower the autosampler arm up to the upper edge of the adjusting aid until the dosing tube just dips into the dosing opening.

Adjustments for X and Z direction are saved in the software.

- Secure the positions of the adjusting screws with lock nuts.
- Remove the adjusting aid and insert the dosing funnel.

Adjust the injection depth in the graphite tube:

- Lower the autosampler arm via the software. The dosing tube dips into the graphite tube.
- Loosen the clamp nut, place the dosing tube onto the tube bottom, check position with furnace camera if necessary, and fasten with clamp nut.
- Move the autosampler arm software-controlled to the optimum dispensing depth (approx. - 0.8 mm for 20 µL sample volume).



Note

For further configurations of the autosampler see the instruction manual "ASpect LS" / section "Technical autosampler parameters".

6.8.3 Populating the sample tray of the AS-GF

1. Populate the positions of the AS-GF as follows:

Positions 1-100	1.5 mL sample cups
Positions 101 – 108	5 mL special cups
2. Place the sample cover with a tight fit.
3. Next step: fill the wash bottle. If necessary, empty the waste bottle and dispose of the waste correctly. Measure.



Note

The population of the sample tray must match the software configuration in the method or in the sample ID.

6.8.4 Uninstalling the autosampler AS-GF

1. Switch off the ZEEnit 650 P!
2. For *HydrEA coupling*:
Remove the reaction gas tube from the titan canula. Remove the titan canula from the autosampler arm, by loosening the clamp nut.
3. Remove the control cable from the socket in the right side wall of the AAS device (autosampler graphite connection).
4. Release adjusting screw 1 and unhook the autosampler AS-GF.

6.9 Notes on installing the automatic solid autosampler SSA600



Caution!

The eccentric back-up rolls must be premounted for hanging the solid autosampler SSA 600 so that they can still be rotated!

5. Use the front free hole on each side for the eccentric rolls.
6. As soon as the SSA 600 is positioned in the MPE mount, press the eccentric roll against the right sample chamber wall and fasten.

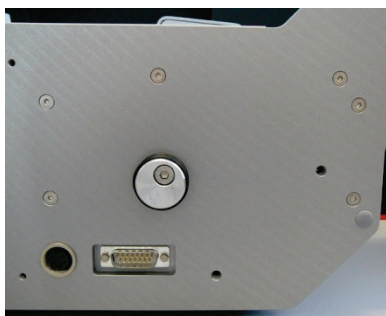

Fig. 32 Position of eccentric roll on the SSA 600

6.10 Installations for Hydride/HydrEA mode



Caution! Switch off the ZEEnit 650 P prior to any installation!

The connection or disconnection of electrical plug-in contacts can cause a short circuit, which destroys the device.

The installation and the operation of the hydride/HydrEA systems is described in the operating instructions of the appropriate accessory systems. These operating instructions are limited to the special features when installing the hydride/HydrEA systems in the AAS ZEEnit 650 P.

6.10.1 Installing the cell unit for hydride systems

1. Loosen the fixing screw (5 in Fig. 25 S. 59), pull out the graphite furnace out of the sample chamber.
2. Plug the support for the cell unit into the intended socket on the base plate of the sample chamber.
3. Insert the cell unit onto the support and fasten with the fixing screw.

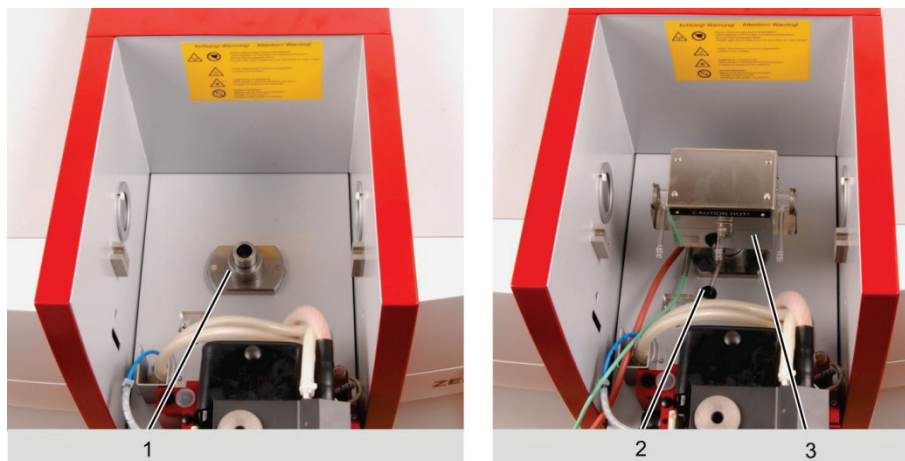

- 1 Support for cell unit 3 Cell unit
2 Fixing screw

Fig. 33 Support and cell unit for hydride system on the ZEE nit 650 P

6.10.2 Installation for continuous hydride/HydrEA mode

In continuous working mode, the samples are loaded via the autosampler AS-F or AS-FD.

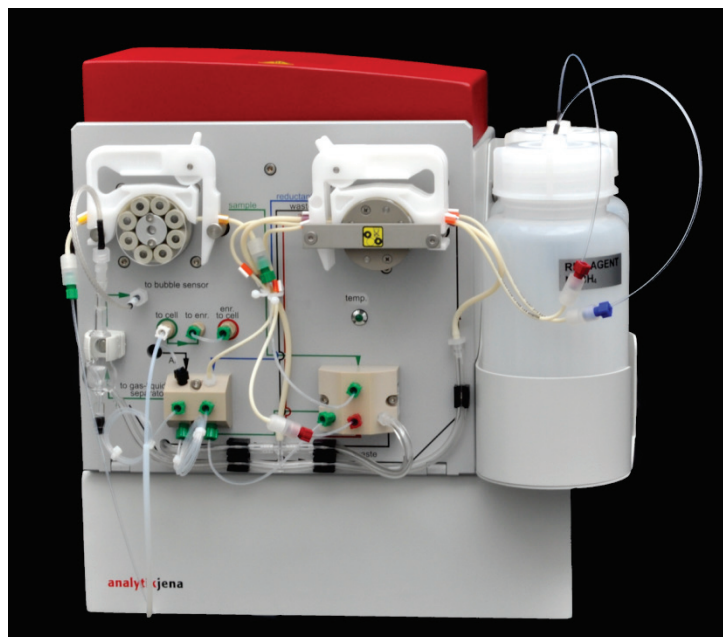

Fig. 34 Hydride system HS 60 modular for hydride/HydrEA measurements

Work steps: Installation

1. Install the hydride/HydrEA systems as it is described in the operating instructions.
2. Plug the control cable into the socket of the autosampler (rear) and fasten.
3. Place the autosampler (with storage bottle or Fluidics module) next to the hydride system.
4. Attach the outlet tube to the outlet connector of the autosampler (rear). Attach the outlet tube to the connector of the receiving bottle.
Note: Position the outlet tube at a constant incline. If necessary shorten the tube.
5. Screw the tube for the washing liquid to the rear of the sampler (5 in Fig. 35).
Note: In the AS-FD the tubes for connecting the autosampler and the Fluidics module are attached to each other by encasing and are numbered. The tubes are attached to the rear of the autosampler using the attachment lug. Marking Wash tube "2".
6. Plug the control cable into the socket on the right side wall of the ZEEnit 650 P (1 in Fig. 17, S. 49) and fasten.
7. Lead the sample aspiration tube through the hose guide part on the autosampler arm on the thin aspirating canula of the autosampler arm.
Note: The autosampler arm can be moved manually.
8. In the AS-FD feed the dosing tube for the diluent (marking "1") through the tube guide at the autosampler arm and plug it onto the thicker canula of the autosampler arm.
9. Lay the sample tray on the autosampler casing, make sure it clicks into place.
Note: The control does not start the autosampler, or stops it automatically, if there is no sample tray.
10. Mount the sample tray.
11. Position the sample cover in such a way that the guiding spout of the autosampler casing takes hold of the groove of the lid.
12. Switch on the ZEEnit 650 P and start the software.



- 1 Fluidics module connection
- 2 AAS connection
- 3 Suspension mount with adjusting screw
- 4 Connector for outlet tube
- 5 Screw for wash tube

Fig. 35 Rear of the autosampler AS-FD

Preparing the Fluidics module (for AS-FD)

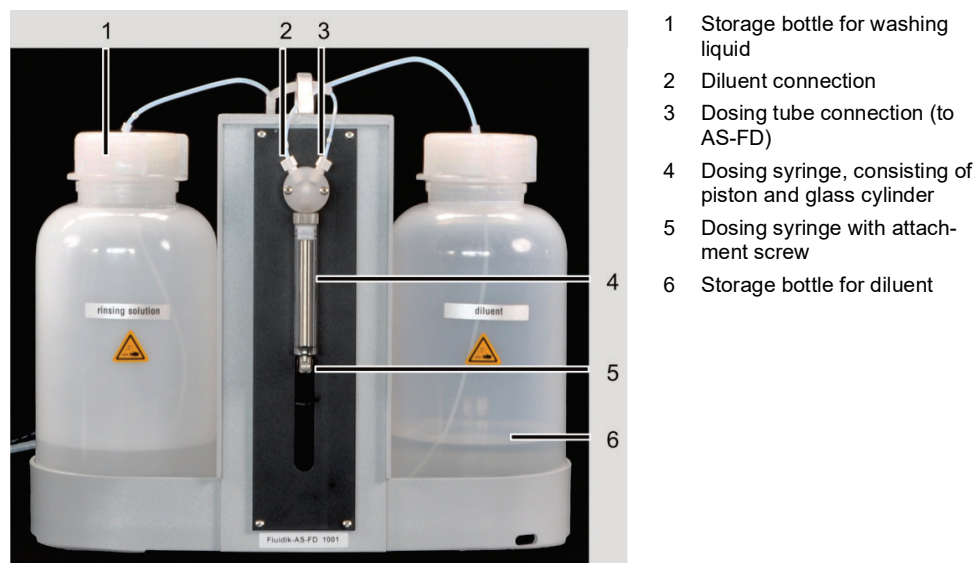

Fig. 36 Dosing unit at the Fluidics module of the AS-FD

1. If necessary, fit the dosing syringe to the dosing unit (→ Section "Replacing the dosing device" p. 89).
2. Place the storage bottles for the wash liquid (left) and diluent (right) into the bottle holders of the Fluidics module.
3. Immerse the short tube (marking at the tube "3") into the storage bottle for the diluent. Screw the second tube end to the valve (2 in Fig. 36).
4. Screw the dosing tube for the diluent (encased, marking "1") to the second connection of the valve (3 in Fig. 36).
5. Immerse the hose for the wash liquid (marking "2") into the storage bottle.

Work steps: Uninstall

1. Switch off the ZEEnit 650 P.

Uninstalling the autosampler

2. Detach the sample intake tube from the thin canula of the autosampler arm.
3. Detach the tube for the wash liquid at the rear of the autosampler.
4. For the AS-FD detach the dosing tube for the diluent from the thicker canula. Pull the two encased tubes out of the attachment lug at the rear of the autosampler.
5. Pull the outlet tube from the connector of the autosampler (backplate).
6. Detach both control cables at the rear of the autosampler.
7. Take the autosampler out of the sample chamber.

6.11 Starting up the ZEEnit 650 P with accessories

6.11.1 Switching on sequence, daily work commencement

1. Switch on the PC and wait for the computer program to initialize: the user icons appear on the screen, including the ASpect LS program icon.
2. Switch on the ZEEnit 650 P: Press the green ON/OFF switch on the right side wall.
3. Start the ASpect LS program: double-click with the mouse cursor on the ASpect LS symbol.
4. Connect the printer if it is needed.

The AAS system is now switched on, work (analysis preparation and measurement) may begin.



Note

The mobile cooling unit KM5 is controlled by the ZEEnit 650 P and is therefore not switched on manually.

6.11.2 Switching off sequence

1. On the PC close the application program Aspect LS: Click the **File / Close** menu options.
2. For unsaved values decide whether unsaved data/information should be saved before exiting the program.
3. Shut down the PC.
4. Use the respective mains switches to switch off (in this order):
 - PC
 - AAS
 - Printer

The AAS system is now switched off.

7 Care and maintenance



Observe the safety instructions!

The operator may not undertake any service or maintenance work to this device and its components other than those specified and described in this chapter.

Only service engineers from Analytik Jena or other technical personnel authorized by Analytik Jena may carry out repairs to the ZEEnit 650 P.

Please observe all guidelines, standards and safety instructions when undertaking any maintenance work as specified in Section "Safety instructions" S. 9.

To guarantee perfect and safe functioning, the ZEEnit 650 P should be inspected on an annual basis by service engineers from Analytik Jena.

Only use replacement parts from Analytik Jena. Parts required for routine operation can be ordered from Analytik Jena.



Danger! Electric shock!

The ZEEnit 650 P must be switched off before carrying out any service work and the **mains plug must be disconnected**. The safe disconnection of the ZEEnit 650 P from the mains can only be achieved by pulling out the mains plug. Power is still supplied to both certain areas of the spectrometer, as well as the output socket, after the device has been switched off at the main switch.

7.1 Maintenance overview

Maintenance item	Action	Frequency
Base device		
Fuse	Change the fuse	When required
Sample chamber	Clean sublimated substances (residues)	Regularly
	Clean the windows for beam entry and -exit in the sample chamber	On visual inspection: Streaks, burnt-in residues When energy losses arise
Graphite furnace		
Graphite tube	Clean by cleaning out (heating up) using the cleaning program of the control software	Daily
Iridium-coated graphite tube	Evaporation of iridium coating	After approx. 500 atomizations or for a new coating (Malfunctions result in falsified measurement results)
Furnace window	Wipe with a lint-free cloth soaked in alcohol To remove stubborn contamination use a commercial cleaning solution for UV cells	Weekly

Graphite electrodes	Clean the contact surfaces of the electrodes with a cotton swab, a lint-free cloth soaked in alcohol, or blotting paper	Regularly
	Check for wear, replace if necessary.	Every six months
Pipetter insert	Clean and wash	May be necessary on a daily basis, depending on the type of samples
Autosampler AS-GF / AS-F and AS-FD		
Dosing tube/canulas	Check for freedom from deposits, kinks and cracks.	Check regularly since sediments can falsify the measurement results
Wash cup, mixing cup	Clean	Regularly
Gas connectors		
	Check for leaks	When connections are newly connected and when a clear pressure loss is detected by the manometer
Mobile cooling unit KM5		
Water container	Check the water level in the water container and fill up with softened water	After emptying, otherwise quarterly
Cooling fins	Keep clean	Permanently

Table 7-1 Maintenance overview

7.2 Base device

7.2.1 Changing the fuses



Switch off the ZEEnit 650 P before replacing fuses!

The fuses of the ZEEnit 650 P are to be found on the rear side of the device. They are marked.

Fuses on the rear (see Fig. 18)

Fuse number	Type	Protected circuit
F1	32 A/T	Power supply
F2	32 A/T	Power supply
F3	T 6.3 A/H	Socket for external accessories
F4	T 6.3 A/H	Socket for external accessories
F5	T 2.5 A/H	Transformer, primary side, NTL
F6	T 2.5 A/H	Transformer, primary side, NTL

F7	T 6.3 A/H	Power supply of the magnet
F8	T 6.3 A/H	Power supply of the magnet
F9	T 0.08 A	D2 HCL
F10	T 0.25 A	HCLs
F11	T 0.08 A	Boost current
F12	T 1 A	Heating for boost current
F13	T 0.032 A	Analog
F14	T 3.15 A	Filament
F1 internal	TR5-T100 mA	Zeeman graphite furnace measuring lead
F1 internal MagPS	FF 4 A/H	Power supply of the magnet



Caution!

The power supply fuses F1, F2 and the internal fuse for the power supply of the magnet (F1 internal MagPS) may only be changed by service engineers from Analytik Jena or by technical personnel authorized by Analytik Jena.

The fuse F1 internal for the Zeeman furnace measuring lead is located readily accessible in the rear of the base of the furnace.

If F1 internal MagPS has melted, the ASpect LS software indicates an error with the magnet control. The software specifies which fuses are to be checked.

7.2.2 Cleaning of sample chambers

1. Clean the sample chamber regularly using a lint-free cloth moistened with alcohol.
2. If there is liquid residue in the sample chamber tray, e.g., from the siphon outlet, pull out, empty then wipe out the sample chamber sump with a dry cloth.
3. Check the radiation entrance and exit windows of the sample chambers if energy losses are detected:
Wipe the windows free of streaks with a lint-free cloth soaked in alcohol (optical cloth).

7.3 Graphite furnace

7.3.1 Maintaining the graphite furnace

After a prolonged operation time, sample residues, modifiers and sublimated carbon particles of the graphite tube are deposited on the contact surfaces of the graphite electrodes, the furnace shroud, the radiation sensor (radiation requires free passage from the graphite tube through the furnace shroud and lower electrode to the sensor) and the pipetter inset. These deposits can be a source of contamination and can lead to increased deviations of the formatting factor. Damaged furnace parts (furnace shroud, graphite tube, electrodes) can be the cause of sub-standard analysis results.



Warning! There is a risk of burning yourself on the hot graphite furnace!

Allow the graphite furnace to cool down before attempting any service or maintenance work.



Caution! Do not touch the quartz panes of the furnace windows with your bare fingers!

Fingerprints burn in.

7.3.1.1 Cleaning the furnace windows

1. Allow the furnace to cool down.
2. Open the furnace and take both furnace windows out of their guide. (The left furnace window can also be removed when the furnace is closed.)
3. Wipe the furnace window with a lint-free cloth soaked in alcohol. To remove stubborn contamination use a commercial cleaning solution for UV cells (order number 407-320.002).
4. Replace the furnace windows in their guides, taking care not to damage the sealing rings.



Caution!

Do not clean the furnace windows in an ultrasonic bath. This may lower the UV permeability of the windows.

Do not touch the quartz panes of the furnace windows with your bare fingers! Fingerprints burn in.

Danger of brittleness for rubber seals. When cleaning the furnace windows with alcohol, make sure that the rubber seals do not come in contact with the alcohol!

7.3.1.2 Cleaning the graphite surfaces

The graphite surfaces must be cleaned after each daily use as required.

1. Switch on the ZEE nit 650 P and start the ASpect LS software (the movable furnace part must be pressurized to be opened/closed).
 - Use the  button to open the **Furnace** window. Go to the **Control** tab.
 - Open the furnace with the **[Open furnace]** button.
2. Remove the pipetter insert from the furnace jacket and clean it in 0.1 - 1 N HNO₃.
Then wash thoroughly with slightly acidic or demineralized water.
5. Clean the contact surfaces of the electrodes with a cotton swab, a lint-free cloth soaked in alcohol, or blotting paper.
6. Clean the inner surfaces of the furnace jacket with a cotton swab.

7.3.2 Separation of the graphite furnace from the Zeeman magnet and reinsertion

To replace the electrodes and furnace shroud, the graphite furnace must be extracted from the sample chamber and the furnace parts separated from the magnet.

Work steps in the separation

1. Loosen the locking screw (cross-head screw, 7 in Fig. 37) for the graphite furnace.

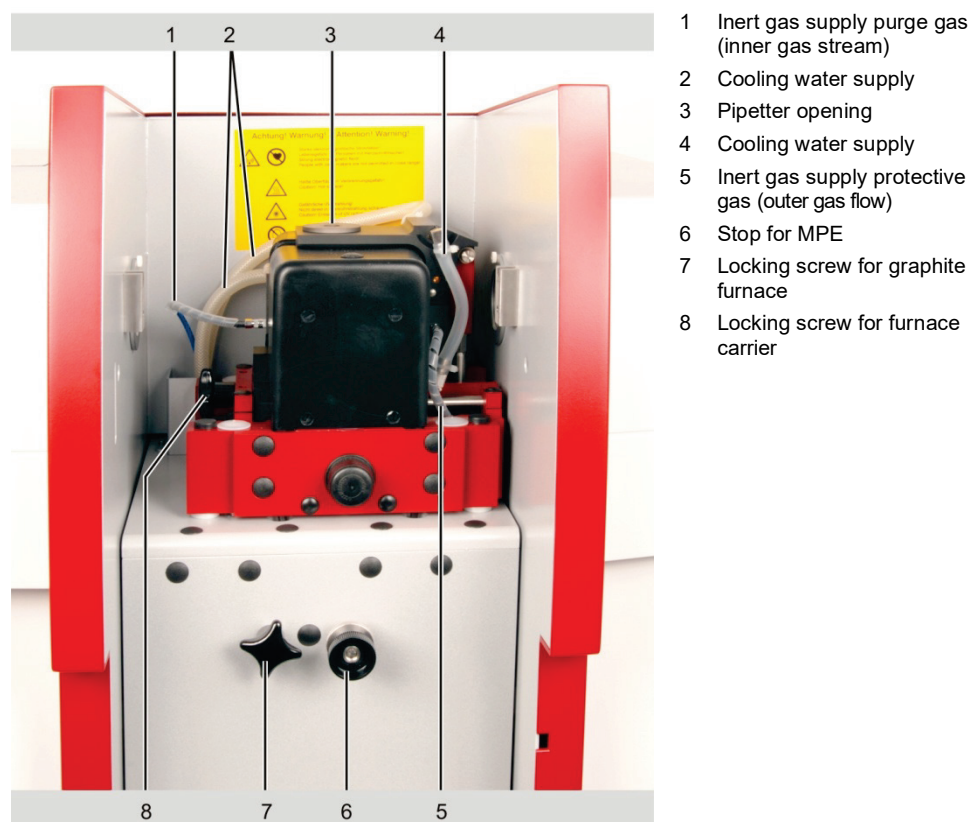

Fig. 37 Locking screws for the graphite furnace



Caution! Danger of collision!

The furnace may not be opened during the following work step!

2. Pull the graphite furnace out of the sample chamber to the end stop.
3. Pull out the left furnace window (2 in Fig. 39) upwards and pull off the gas tube (1 in Fig. 39) from the connector below the furnace window.

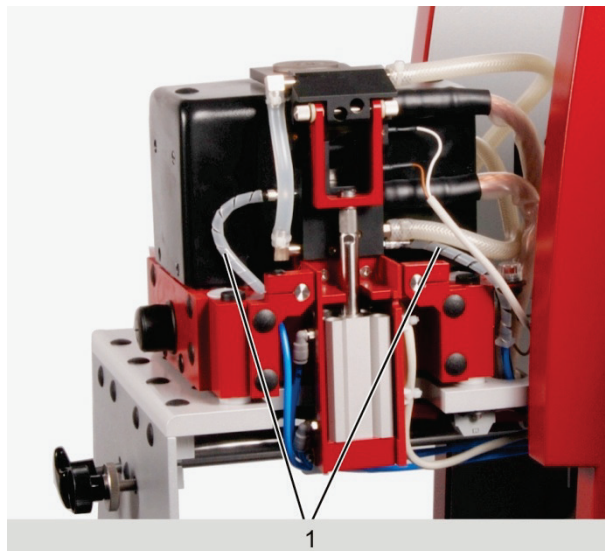

1 Tubes on the right

Fig. 38 Driven-out furnace, right side

4. Pull off both tubes on the right of the furnace.
5. Remove the pipetter insert (3 in Fig. 39) from the swiveling part of the furnace.

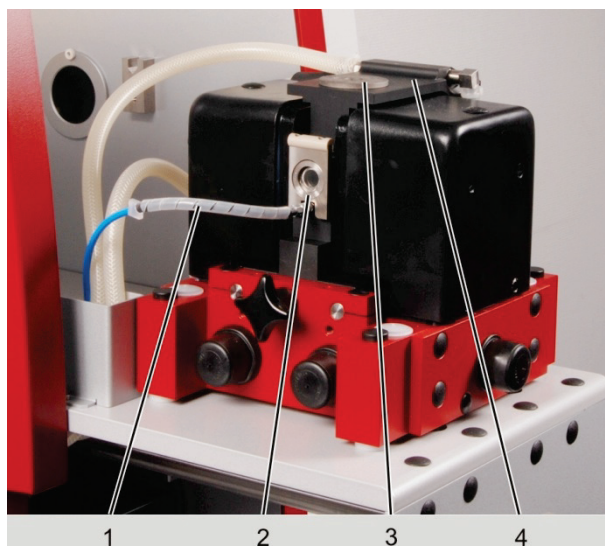

1 Argon tube
2 Left furnace window
3 Stopper (here: pipetter insert)
4 Swiveling part of the furnace

Fig. 39 Driven-out furnace

6. Using ASpect LS, open the graphite furnace with the **[Open furnace]** button in **Furnace – Control** window.
7. Take out the graphite tube.

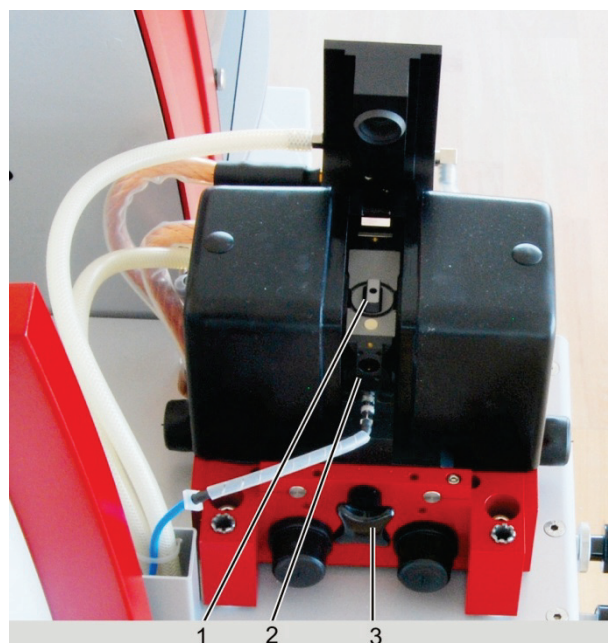

- 1 Graphite tube
- 2 Sealing plate for left furnace window
- 3 Cross-head screw, furnace carrier

Fig. 40 Driven-out furnace, open, left side

8. Unscrew the sealing plate (2 in Fig. 40) for the left furnace window (4 titan slotted-head screws).
9. Loosen the cross-head screw (3 in Fig. 40) to the left of the furnace carrier.
10. Press the furnace carrier carefully by hand to the right out of the fixed magnets.

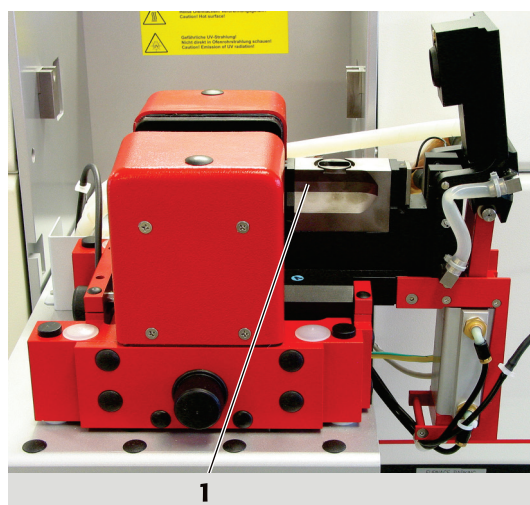

- 1 Furnace shroud

Fig. 41 Driven-out furnace carrier

The furnace is now ready for maintenance work, furnace shroud and electrodes are easily accessible. Once the maintenance is complete, bring the furnace back to its original position:

Work steps to bring the furnace to the working position

1. Press the furnace carrier by hand back between the pole shoes (2 in Fig. 42) of the Zeeman magnet.
2. Screw the furnace carrier finger tight with the cross-head screw (3 in Fig. 40).

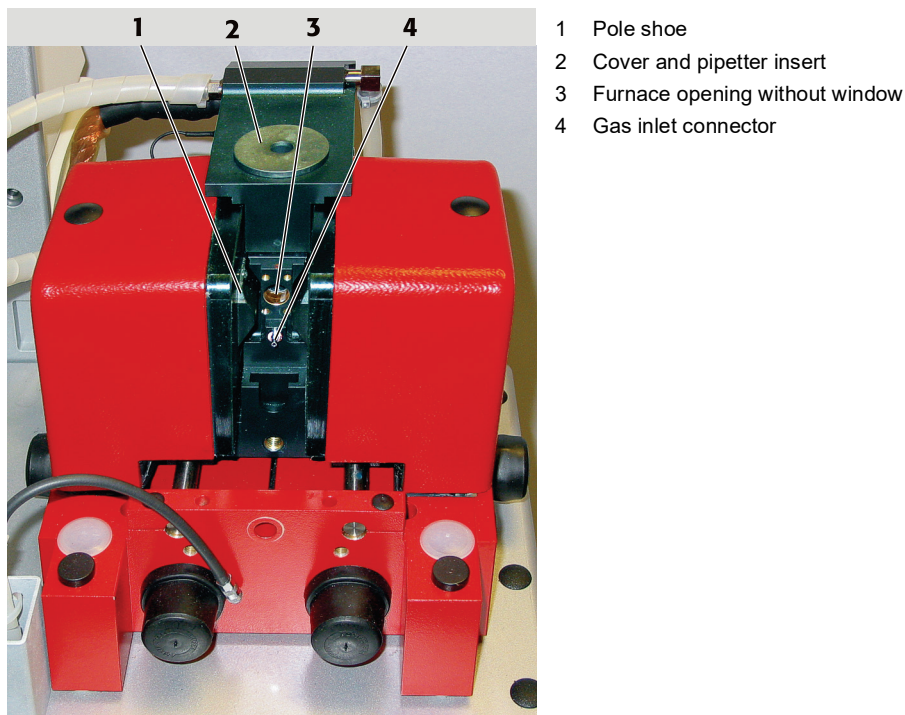

Fig. 42 Furnace partially pressed out of the Zeeman magnet

3. Screw on the sealing plate for the left furnace window.
4. Attach the gas tube onto the connector (4 in Fig. 42) below the furnace window (quick connector).
5. Attach both gas tubes onto the right side of the furnace (Fig. 38).
6. Set the left furnace window into the guide on the furnace.
7. Slide the graphite furnace into the sample chamber as far as the end stop and lock in place.

7.3.3 Removing and cleaning the temperature sensor group

The temperature sensor must be removed before changing the electrodes. The sensor for temperature recalibration is mounted from below in the bottom furnace part. The temperature sensor senses the radiation through the openings in the furnace shroud and in the lower electrode directly from the graphite tube.

1. Loosen the two knurled screws (1 in Fig. 43) at the bottom of the furnace.
2. Pull the sensor group (2 in Fig. 43) out of the holder. Make sure that the sealing ring on the sensor is not lost.
3. Clean the front of the radiation sensor with a lint-free cloth soaked in alcohol.

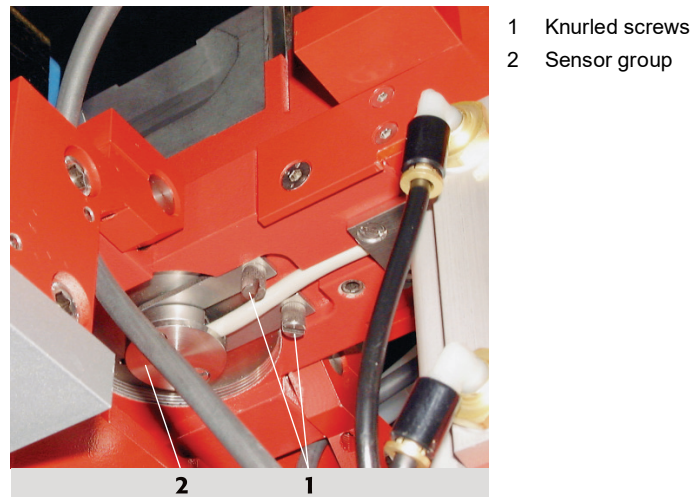
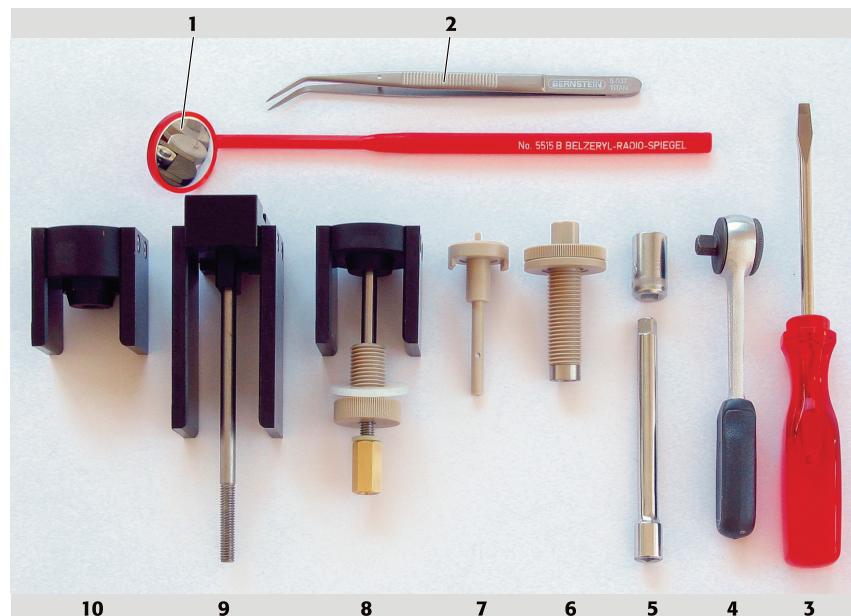

Fig. 43 View of the furnace with radiation sensor module from below

At this point, change the lower electrode and the furnace shroud if necessary, then replace the sensor group in reverse order. Make sure that the sealing ring is inserted. Tighten the knurled screws only finger tight.

7.3.4 Replacing the upper electrode

The electrodes must always be replaced in pairs, either as required or if there is a formation error > 10 also after cleaning the electrodes and changing the graphite tube. The furnace tools are not included in scope of supply and can be ordered as an option. The electrodes can also be changed by service engineers.



- | | |
|---|---|
| 1 Hand mirror | 7 Graphite tube adjusting aid |
| 2 Tweezers | 8 Pressure piece for lower electrode with short spindle, flange nut and spindle nut |
| 3 Screwdriver | 9 Pressure piece for furnace shroud with longer spindle |
| 4 Ratchet wrench for hexagonal bit | 10 Pressure piece for upper electrode |
| 5 Hexagonal shroud bit and extension | |
| 6 Press-out tool for electrodes and furnace | |

Fig. 44 Furnace tools

- Press out the upper electrode with the press-out tool: Screw the press-out tool (6 in Fig. 44) as far as the stop in the furnace jaw using a ratchet wrench (4 in Fig. 44). Keep carefully rotating the press-out tool in until the electrode falls out of the electrode holder. Unscrew the press-out tool from the jaw.

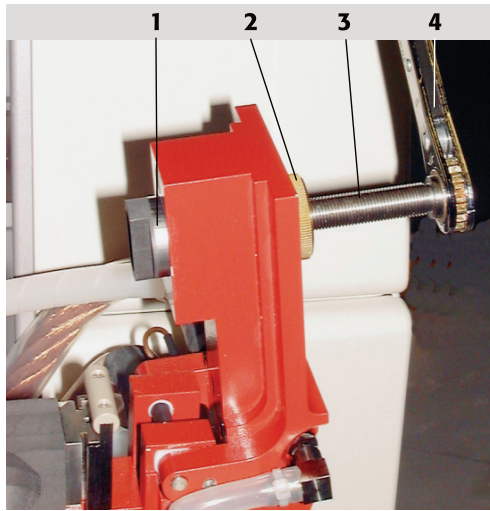

- 1 Electrode
- 2 Flange nut
- 3 Spindle
- 4 Ratchet wrench

Fig. 45 Electrode, partially pushed out

- Screw in the flange nut (3 in Fig. 46) of the insertion tool as far as the stop in the furnace jaw.



Caution! Risk of destroying the electrode.

Make sure that the electrode and the furnace jaws are parallel when positioning and inserting the electrode. If the electrode is unintentionally skewed, remove completely and start again.

- Insert the shorter spindle into the pressure piece "upper electrode". Lead a new electrode over the spindle. Lead the pressure piece "upper electrode" with spindle and electrode into the furnace jaw, slide the pressure piece over the furnace jaw and align the electrode. Screw the spindle nut with washer by hand onto the free spindle end as far as the stop. Insert the electrode into the jaws as far as the fixed front rest, using the spindle nut and the ratchet wrench.

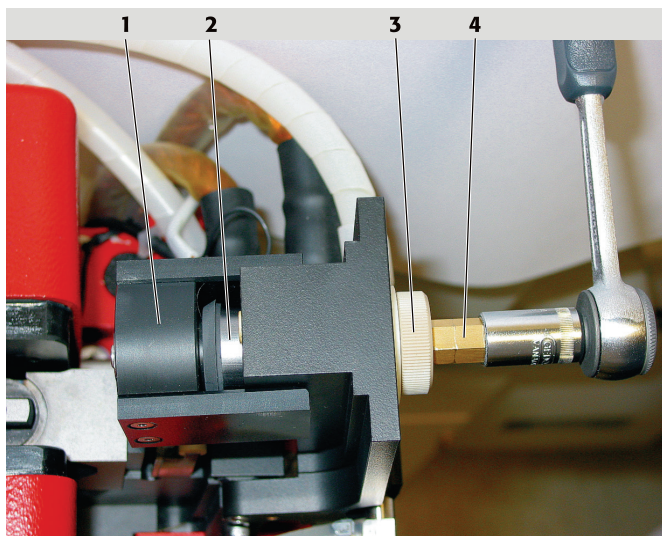

- 1 Pressure piece
- 2 Electrode
- 3 Flange nut
- 4 Spindle nut

Fig. 46 Electrode with insertion device, mounted on the jaw

7. Unscrew and remove the spindle nut completely, to do so hold the pressure piece with your left hand and pull out. Unscrew the flange nut.
8. Remove by suction or blow away any graphite dust which is present.

7.3.5 Replacing the graphite tube shroud and the lower electrode

The graphite tube shroud and the lower electrode have to be replaced:

- When damaged
- When contamination cannot be removed by cleaning
- If the formation factor of >10 remains after cleaning the electrode and changing the graphite tube.

The electrodes must always be replaced in pairs!

1. Separate the graphite furnace from the Zeeman magnets (→ Section "Separation of the graphite furnace from the Zeeman magnet and reinsertion" S.77).
2. Remove the temperature sensor group (→ Section "Removing and cleaning the temperature sensor group" S.80)
3. Screw in the press-out tool (6 in Fig. 44) in place of the removed temperature sensor as far as the stop.

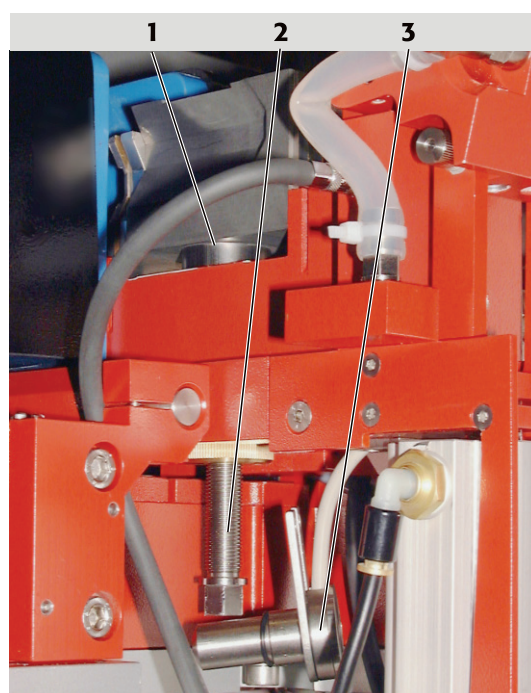

- 1 Furnace shroud, cylindrical attachment is partly visible
- 2 Press-out tool
- 3 Removed sensor group, hanging on the cable

Fig. 47 Furnace shroud, partly pressed out

4. Turn the spindle of the press-out tool with the ratchet wrench. When pressing out, guide the furnace shroud with your hand. Take out the furnace shroud and the lower electrode.
5. Unscrew the press-out tool from the furnace and then screw in the flange nut of the insertion tool in the same position as far as the stop.
6. Insert the shorter spindle into the pressure piece "lower electrode".

7. Attach a new lower electrode onto the spindle. Guide the pressure piece "lower electrode" with spindle and electrode into the furnace carrier, sliding the pressure piece over the furnace carrier and lining up the electrode with the opening.
8. Screw the spindle nut with washer onto the free spindle end as far as the stop.

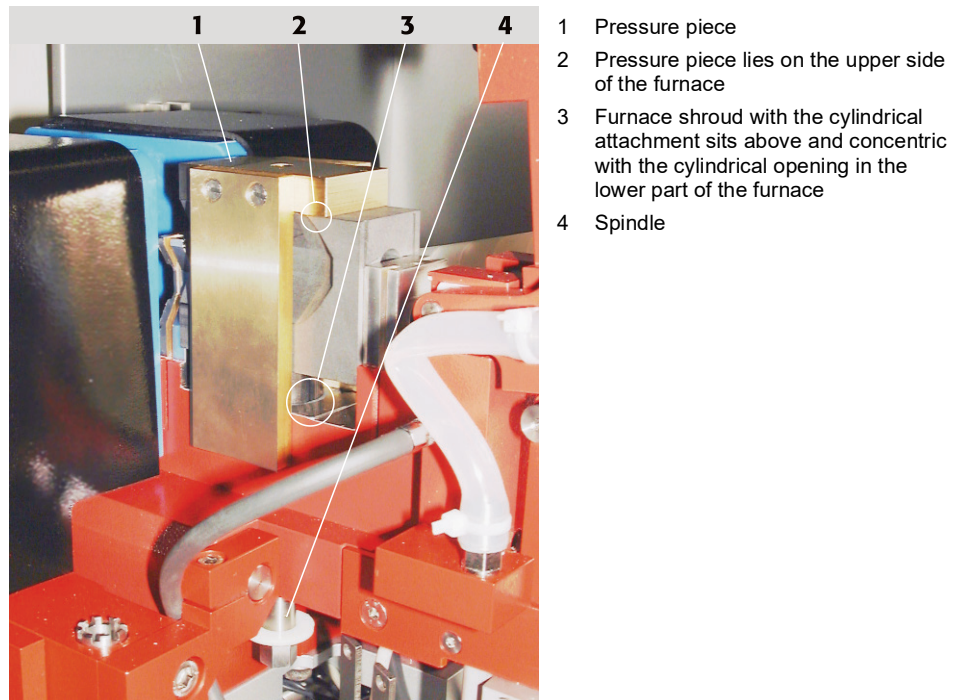

Fig. 48 Furnace shroud ready for insertion



Caution! Risk of destroying the electrode.

Make sure that the electrode and the furnace jaws are parallel when positioning and inserting the electrode. If the electrode has been inadvertently inserted at a skewed angle, press out completely and start again.

9. Insert the electrode into the furnace carrier as far as the fixed front rest, using the spindle nut and the ratchet wrench.
10. Loosen the spindle nut and unscrew. Remove the pressure piece "lower electrode" and the spindle. Remove by suction or blow away any graphite dust which is present.
11. Leave the flange nut of the insertion tool in the furnace shroud.
12. Attach the long spindle into the pressure piece "furnace shroud".
13. Set the new furnace shroud onto the opening of the furnace carrier. Lead the pressure piece "furnace shroud" with spindle over the furnace shroud and furnace part so that the rectangular key in the opening on the upper side of the furnace shroud protrudes and the side pressure surfaces of the pressure piece lie on the furnace top side.
14. Screw the spindle nut with washer onto the free spindle end as far as the stop.



Caution!

Danger of destruction for the furnace shroud if the torque increases abruptly during insertion. Ensure that the furnace shroud and the lower part of the furnace are always parallel to each other. If the furnace shroud is skew, press it out completely and start again.

15. Screw in the spindle nut with the ratchet wrench and insert the furnace shroud up to the stop.
16. Loosen the spindle nut and remove. Remove the pressure piece and spindle. Remove by suction or blow away any graphite dust which is present. Screw out the flange nut.
17. Install the cleaned radiation sensor. Screw in the two knurled screws finger tight.
18. Insert a graphite tube with tweezers.
19. Close the graphite furnace using ASpect LS with the **[Close furnace]** button in **Furnace - Control** window.
20. Bring back the graphite furnace according to Section "Separation of the graphite furnace from the Zeeman magnet and reinsertion" S. 77 to its original position.

7.3.6 Cleaning and changing the graphite tube

Clean the standard graphite tube

Daily

Work steps, see Chapter "Cleaning the graphite tube / (clean out)" S.62.

Clean the iridium-coated graphite tube

Daily

Work steps, see Chapter "Cleaning the graphite tube / (clean out)" S.62.

Evaporation of iridium coating in the graphite tube

After approx. 500 atomizations or for a new coating.

Work steps, see Chapter "Cleaning the graphite tube / (clean out)" S.62.

Replace the graphite tube

If the graphite tube appears to be burnt, the pyrolytic coating is worn out.

At a formatting factor > +10 % an automatic temperature correction no longer takes place. Further use of the graphite tube should only be done with caution. The graphite tube should be changed or the temperature should be manually adapted in the furnace program.

Work steps, see Chapter "Inserting the graphite tube into the graphite furnace" S.60.

7.4 Autosampler AS-GF

The following maintenance work must be performed on the AS-GF:

- Remove any contamination from the sample tray and the casing with a dry cloth on a daily basis.
- Wash, service, replace the dosing tube.
- Clean, after a wash or mixing cup has overflowed.

7.4.1 Washing the dosing tube

The dosing tube must be washed prior to and after work. Washing solution is taken from the storage bottle, pumped via the dosing syringe into the dosing tube and dispensed into the wash cup.

1. Switch on the ZEE nit 650 P and start the ASpect LS software.
2. In ASpect LS open the window **Autosampler** with .
3. Use the **[Wash]** button to start the wash cycle.

Note: If the dosing tube is not immersed properly into the wash cup during washing, the autosampler must be realigned in the wash position.

4. In the window **Function tests** enable the button **[Adjust autosampler]**. In the area **Alignment position** enable the option **Wash position**. In the area **Alignment Wash position** enter the immersion depth in the list field (approx. 40 mm). Correct the alignment of the swivel arm with the arrow keys. Save the configurations and exit the window.
Caution: When opening the window **[Adjust sampler]** again, a value of **13 mm** is shown under **Depth**, not the stored value.
5. The wash cycle can be repeated several times if required.

The wash cycle can be defined in the method and thus performed automatically prior to and after the measurement.



Note

If a method is active, pressing the **[Wash]** button in the **Autosampler** window results in the processing of the number of Wash cycles set the method.

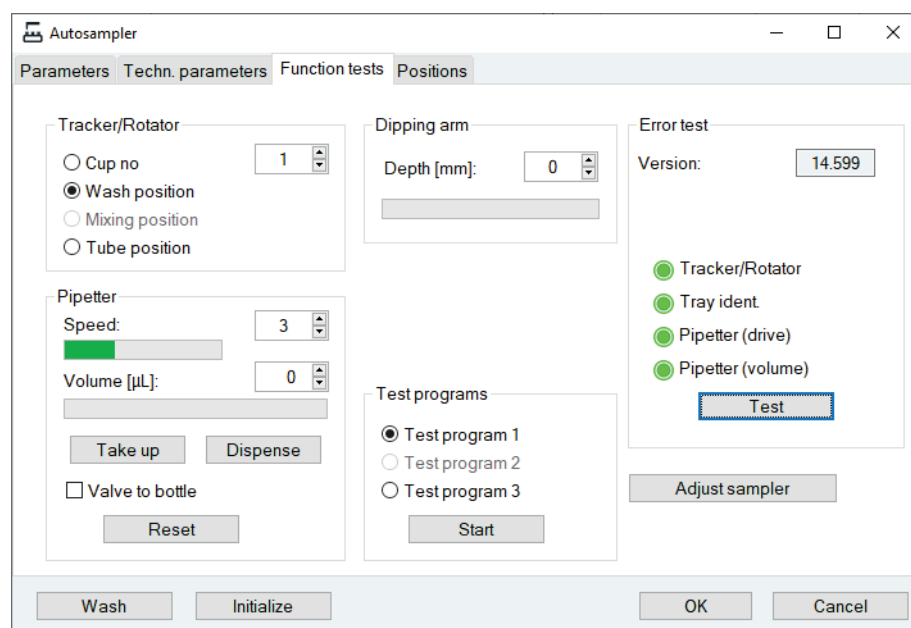

Fig. 49 Window "Autosampler / Function tests" in the ASpect LS software

7.4.2 Servicing the dosing tube

A defective or kinked dosing tube or one with sediment deposits can be the cause of distorted measurement results.

Maintenance work is:

- Cleaning the dosing tube
- Shorten the dosing tube
- Replace the dosing tube

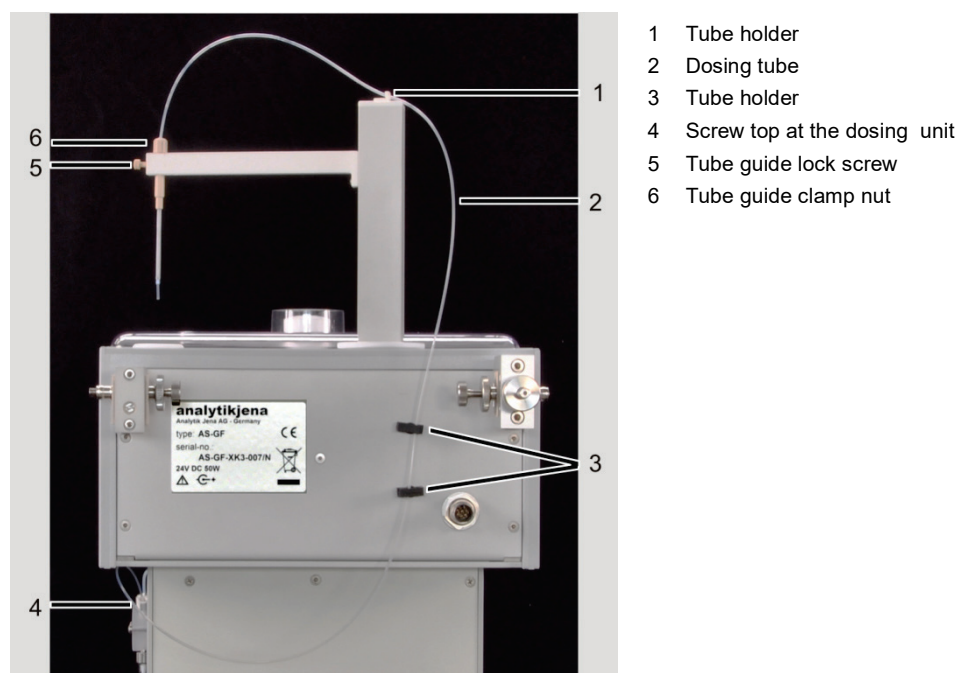



Fig. 50 Dosing tube at the AS-GF

Cleaning the dosing tube

The dosing tube requires cleaning, dependent on the sample material, when:

- The pH levels of the sample, the wash liquid and the air bubble are blurred, or if the bubble is segmented.
- The sample is spread out in the tube (tube is contaminated on the inside).

An 8 to 13% sodium hypochlorite solution (NaOCl) is recommended as a cleaning solution. The following cleaning procedure should be repeated as often as is necessary.

1. Fill the sodium hypochlorite solution into a 5 mL special cup and mount tray position 101 with it.
2. Switch on the ZEE nit 650 P and start the ASpect LS software.
3. In ASpect LS open the window **Autosampler** with . Change to the tab **Function tests** (Fig. 49).
4. In the area **Tracker/Rotator** enter "101" into the list field and enable the option **Cup no.**
The autosampler arm moves to position "101".
5. In the area **Dipping arm** in the list field **Depth** lower the autosampler arm into the special cup with the arrow keys (approx. 50 mm).
Note: The autosampler is only lowered if the arrow keys are used. After entering the value directly into the list field, click the arrow keys once again!
6. In the area **Pipetter**, in the list field **Volume [µL]**, use the arrow keys to set the volume to be picked up (approx. 100 - 200 µL). The volume can be set in steps of 50 µL.
7. Press the button **[Take up]**. The autosampler fills the dosing tube with the cleaning liquid.
8. Allow the cleaning liquid to work for approx. 20 min.
9. In the area **Tracker/Rotator** enable the option **Wash position**.
10. The autosampler arm moves to the wash position.
11. In the area **Dipping arm** in the list field **Depth** lower the autosampler arm into the wash cup with the arrow keys (approx. 40 mm). When entering the value directly into the list field, click the arrow keys once again!
12. Use the **[Dispense]** button to empty the dosing tube into the wash cup.
13. Start 5 wash cycles. (Click the **[Wash]** button 5 times.)

Shortening the dosing tube of the AS-GF

1. Loosen the clamp nut at the tube guide (6 in Fig. 50) and remove the dosing tube by pulling upwards.
2. Cut the dosing tube with a razor blade or a scalpel at an angle of 10° to 15°.
3. Push the dosing tube as far as possible into the tube guide until the dosing tube protrudes by approx. 8 mm at the bottom.
4. Lock the dosing tube with the clamp nut.
5. Readjust the injection depth of the sample (→ section "Adjusting the AS-GF" p. 66).

Replacing the dosing tube of the AS-GF

1. Loosen the clamp nut at the tube guide (6 in Fig. 50) and pull out the tube. Remove the tube from the tube holders at the sample arm and the back of the autosampler (1 and 3 in Fig. 50).
2. Detach the screw top from the T valve of the dosing unit (4 in Fig. 50).
3. Screw the new dosing tube to the valve and feed it through the tube holders.
4. Push the dosing tube into the tube guide until it protrudes 8 mm at the bottom, lock with the clamp nut.
5. Readjust the injection depth of the sample (→ section "Adjusting the AS-GF" p. 66).

7.4.3 Replacing the dosing device

The details below apply to the samplers AS-GF (graphite tube) and AS-FD (flame). The dosing units only differ in the size of the dosing syringe (500 or 5000 μL).

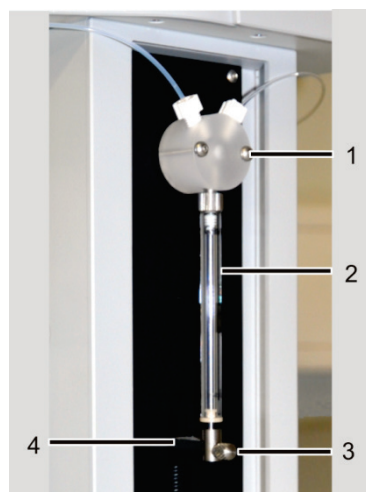

- 1 T-Valve
- 2 Dosing syringe, consisting of piston and glass cylinder
- 3 Attachment screw
- 4 Drive rod

Fig. 51 Dosing unit at AS-GF and AS-FD

1. Switch on the ZEEnit 650 P and start the ASpect LS software. In the window **QuickStart** Select technique: **Graphite furnace** (AS-GF) or **Flame** (AS-FD).
2. Use  to open the **Autosampler** window. Change to the tab **Function tests**.
3. In the **Pipetter** area, in the list field **Volume [μL]**, use the arrow keys to set the volume to be picked up (AS-GF: 500 μL ; AS-FD 5000 μL). Increase the speed to 6-7.
4. Press the button **[Take up]**.
The piston of the dosing syringe moves down.
5. Unscrew the fixing screw (3 in Fig. 51).
6. Unscrew and remove the dosing syringe (2 in Fig. 51).
7. Screw the new dosing syringe to the valve.
8. Carefully pull the piston down until the eyelet at the piston end is aligned with the hole in the drive rod.

9. Screw the piston with the attachment screw finger-tight to the drive rod.
Caution: Excessive force can lead to material damage! Do not tighten the screw too much.
10. In the window **Autosampler** click on the **[Initialize]** button.
The piston of the dosing unit moves back to the original position.

7.4.4 Clean-up after cup overflow

If during the process a wash cup has overflowed, immediately interrupt the process and clean the device.

1. Stop the process immediately.
2. Take up the liquid with cellulose wadding or cloth. Wipe the surface dry.
3. Ensure that the outlet can be drained, i.e., remove any sharp bends in the draining tube or make sure that the draining tube does not dip into the liquid in the waste bottle.

7.5 Autosampler AS-F, AS-FD

Contamination on the tray and the casing can be removed with a dry cloth on a daily basis as required. In addition according to conditions:

- Washing the sample paths
- Wash the mixing cup
- Replace the canula(s) at the autosampler arm
- Replace the aspiration tube and dosing tube
- Replace the dosage syringe, as for AS-GF (→ Section "Replacing the dosing device" p. 89)
- Clean, after a wash or mixing cup has overflowed

7.5.1 Washing the mixing cup of the AS-FD

The mixing cup must be washed before and after the operation to prevent adhesion and scaling. Before preparing the first standard / first sample the mixing cup is washed automatically. Further washing processes might be useful during continuous operation.

Washing the mixing cup prior to and after the measurement

1. In ASpect LS open the window Autosampler with .
2. In the tab Techn. parameters enter a volume of 25 mL in the group Wash mix cup.
3. Use the [Start] button to start the wash cycle.
4. The wash cycle can be repeated several times if required.

25 mL of washing liquid is dispensed from the storage bottle into the mixing cup and automatically drained off afterwards.

Washing the system prior to an extended period of decommissioning

If salts were added to the diluent (bidistilled or acidic bidistilled water), the dosing unit and valve must be washed with methanol or ethanol prior to extended periods of decommissioning. Otherwise scaling and blocking may also occur.

1. Fill the storage bottle for the diluent with methanol or ethanol.
2. Perform the wash cycle as described in Section "Washing the system prior to and after the measurement". Repeat the washing process several times.

7.5.2 Replacing the canulas and guide on the autosampler arm of the AS-FD

The canulas and guide must be replaced if there is a significant contamination or mechanical damage (detectable by large standard deviations in the measurements).

1. Pull off the hoses from the canulas.
2. Loosen the fixing screw on the autosampler arm.
3. Pull the canula guide with canulas upwards and out.
4. Fit the guide with the new canulas into the autosampler arm and fix in place with the locking screw.



Caution! Risk of fracture!

Set the canula height for them to terminate 1-2 mm above the block with the wash and mixing cup.

5. Plug the sample intake tube onto the thinner canula. Plug the dosing tube for the diluent onto the thicker canula.

7.5.3 Replacing the canula on the autosampler arm of the AS-F

The canula for picking up the sample (thin canula) must be replaced if there is a significant contamination or mechanical damage (detectable by large standard deviations in the measurements).

1. Pull the intake tube off the canula.
2. Loosen the lock screw at the autosampler arm and pull out the canula.
3. Insert the new canula and fix with the clamp nut.



Caution! Risk of fracture!

Set the canula height for it to terminate 1-2 mm above the washing cup.

4. Plug the intake tube onto the new canula.

7.5.4 Replacing the intake tube

If the intake tube is contaminated, it must be replaced.

1. Pull off the intake tube from the thinner canula at the autosampler arm and then from the nebulizer canula.
2. Cut a new tube to the required size and attach it on both canulas.

7.5.5 Replacing the tube set at AS-FD

1. Pull the dosing tube for diluent off the thicker canula at the autosampler arm and feed it through the tube guide.
2. Detach the tube for the washing liquid at the rear of the autosampler.
3. Pull the encased tubes out of the attachment lug at the rear of the autosampler.
4. Pull the tube for the washing liquid off the storage bottle.
5. Unscrew the dosing tube from the change-over valve..
6. Screw the new tube set with dosing tube (marking "1") to the change-over valve and attach the encased tubes with the attachment lug to the rear of the autosampler.
7. Insert the tube with the marking "2" into the storage bottle for the washing liquid.
8. Screw the tube for the washing liquid to the rear of the autosampler.
9. Slide the other end of the dosing tube through the tube guide onto the thicker canula of the autosampler arm.

7.5.6 Clean-up after cup overflow

If during the process the washing cup or mixing cup (with AS-FD) has overflowed, immediately interrupt the process and clean the device.

1. Stop the measuring process immediately.
2. Take up the liquid with cellulose wadding or cloth. Wipe the surface dry.
3. *Washing cup*: Ensure that the outlet can be drained, i.e., remove any sharp bends in the draining tube or make sure that the draining tube does not dip into the liquid in the waste bottle.

Mixing cup (only for AS-FD):

Use  to open the **Autosampler** window. Change to the tab **Function tests**.

In the area **Pumps** enable the checkbox **Mix cup pump** to start the pump.

Run the pump until the liquid has been drained off.

Disable the checkbox **Mix cup pump**, to stop the pump

7.6 Mobile cooling unit KM 5



Note

Please observe the maintenance and care instructions in the separate instruction manual "Mobile Cooling Unit KM 5".

Maintenance work

- Check the level and cleanliness of the cooling liquid every three months.
- If air bubbles occur in the cooling circuit (noticeable by the sound) check the water level.

Empty

1. Keep a receptacle with a capacity of 5 L readily available.
2. When the ZEEnit 650 P is switched off, position the back flow tube of the KM 5 (connection is indicated by  on the KM 5) in the receptacle.
3. Switch on the KM 5.
The water cooler is pumped out (emptied).

Fill and ventilate

1. Open the top of the KM 5 and remove the lid of the fill opening.
2. Fill up with 5 liters of softened water using a funnel (up to approx. 5 cm below the lid).
3. Place the back flow tube in the coolant container of the KM 5.
4. Switch on the KM 5. Allow the water cooler pump to run until the returning water is free of air. Switch the KM 5 on and off several times, as required.
5. Switch off the KM 5. Reconnect the back flow tube to the KM 5. Close the filling opening and the lid of the KM 5.

7.7 Supply connections

See Section "Supply and control connections" S.48

Maintenance work

Check the gas mains for air-tightness:

- Weekly as a safety check.
 - If the manometer indicates a clear pressure drop after shutting off the stop cock in the gas mains supply.
 - If a gas connection is open when operation is started up again.
1. Brush connections with a thickly foaming liquid (e.g., soap). If bubbles form at the gas connections when starting up, switch off the ZEEnit 650 P and disconnect the gas supply.
 2. Tighten the gas connections, observing the correct positioning and check again for gas leaks.

8 Transporting the ZEEnit 650 P

Auxiliary materials

- 4 handles
- 19 mm open-end wrench (included in scope of supply)



Risk of injury if the device falls!

Handles which are screwed in too loosely may cause damage during transport. Screw in the handles up to the end stop.



Danger!

The device must be transported by at least 4 persons using the fixed screw-in carrying handles (included in scope of supply). The ZEEnit 650 P is too heavy for two persons (→ Section "Safety instructions" S. 9. In addition, it is not possible to get an adequate grip for transport without the screw-in handles. There is a risk of injury if transport is attempted without using the handles or by too few people.

-
1. Uninstall all components, see Chapter "Installation and start-up" S.48. Ensure that the outlet tube has been removed from the sample chamber.
 2. Close the gas supply upstream of the device connections.
 3. Loosen the gas connector on the rear of the ZEEnit 650 P:
 - Undo the argon tube from the tube couplings.
 4. Undo the quick releases on the cooling water tubes.
 5. Disconnect the electrical connections.



Caution!

Do not tilt the mobile cooling unit. If it cannot be transported in an upright position or if long distance transport is necessary, empty the mobile cooling unit KM5.

-
6. Empty the mobile cooling unit (→ Section "Mobile cooling unit KM 5" S.93)
 7. Remove the four stoppers from the holes for the handles on both sides of the device and keep in a safe place.
 8. Screw the four handles securely into the holes as far as the end stops.

9 Waste disposal

Atom absorption spectrometry usually creates only liquid waste. The liquid waste contains metal ions or heavy metal ions, but mostly different mineral acids which were used during sample preparation. For safe removal of this waste, all solutions must be neutralized, for example with a diluted sodium hydroxide solution.

The neutralized waste must be brought to the appropriate waste disposal center for correct disposal according to the appropriate legal guidelines.

At the end of its service life, the ZEE nit 650 P and all its electronic components must be disposed of as electronic scrap in accordance with valid regulations.

Please dispose of the hollow cathode lamps (HCL) in accordance with the local requirements or contact Analytik Jena service personnel.